



PHASE ONE

MUP  
C  
S  
L

HOYAKUBA  
PHASE ONE

### **On rights**

©2009 Phase One A/S. All rights reserved. Made in Denmark.  
Ver. 1.00 - Updated December 7 2009

Learn more about Capture One 5 on [www.phaseone.com](http://www.phaseone.com)  
Learn more about Phase One 645DF on [www.phaseone.com/camera](http://www.phaseone.com/camera)  
Cover and back images Photo by: Photo & Co.

Special Thanks:  
Søren Jonesen, Photo & Co  
Katie Hawthorne  
Peter Tirsgaard

### **On liability**

The information in this user guide is provided “as is”.  
Under no circumstances, including negligence, shall Phase One be liable for any incidental, special, direct, indirect or consequential damages arising out of or relating to use of the information provided in this guide with or without the software described in the guide.

Specifications and appearances are subject to change without notice.

### **Trademarks & acknowledgements**

Capture One and Phase One are either registered trademarks or trademarks of Phase One A/S in the European Union and/or other countries.

All other trademarks are the property of their respective owners.



## Contents

1.0	Introduction	4	5.0	Tethered shooting	62
1.1	Open Platform – Freedom of Choice	4	5.1	Connecting	62
1.2	Warranty	5	5.2	Driver set-up	62
1.3	Recommended hardware	5	5.3	Tethered operations	63
1.4	Installation and Activation of software	6	6.0	The Back	64
1.5	Deactivation of Capture One 5	8	6.1	CF card usage	66
1.6	Screen calibration	9	6.2	Mounting and dismounting card on computers	69
2.0	The Body - the system	10	6.3	Navigating the Back menu	71
2.1	Unpacking the 645DF system	10	6.4	Playmode	74
2.2	Batteries for camera	12	6.5	Playmode – zoom functions	75
2.3	Batteries for the back	14	6.6	Menu Mode	77
2.4	Attach and remove lens	15	7.0	Custom function	88
2.5	Adjusting the Strap	16	7.2	Types of custom functions	90
2.6	Attaching the back	17		Custom Functions overview	93
2.7	The parts of the camera system	18	7.3	Custom Dial Modes C1, C2 or C3	94
2.8	The displays	19	8.0	Lenses and Multi Mount	96
2.8	Display abbreviations	20	8.1	Functions of the Phase One lens	96
2.9	The buttons on the back	21	8.2	Function of the Phase One lens adaptor	97
2.10	LED lights	21	8.3	List of alternative lenses	98
2.11	Setting date and time	22	8.4	Lens Cast	99
2.12	Setting diopter	23	8.5	4 simple steps to calibrate on fixed lenses (MAC)	100
2.12	Eyeiece shutter	24	8.6	Large format and stitched images (MAC)	100
3.0	Basic functions	26	8.7	4 simple steps to calibrate on fixed lenses (PC)	101
3.1	Setting ISO	26	8.8	Large format and stitched images (PC)	102
3.2	Easy Photography	27	9.0	Software	104
3.3	Measuring light – Exposure Metering	29	9.1	Getting started	104
3.4	Focus modes	30	9.2	Importing from CF card	105
3.5	Using focus lock and infrared focusing	35	10.0	Large format and technical cameras	106
3.6	Shutter release modes	37	10.1	Large format photography	106
3.8	Exposure on Leaf shutter vs. Focal plane	42	10.2	Technical cameras	107
3.8	Flash photography	43	11.0	Maintenance	108
3.9	Flash compensation settings	46	11.1	changing the focusing screen	108
	Flash Photography with electronic flash models other than Metz	47	11.2	Battery socket	109
4.0	Advanced functions	49	11.3	Tripod/Electronic shutter release contact	109
4.1	Exposure Compensation	49	11.4	Camera display error-notification	110
4.2	AE Lock	50	11.5	Lens maintenance	111
4.3	Auto Bracketing	52	11.6	Back Maintenance	111
4.4	Taking photos with the mirror up	54	11.7	housing specification	112
4.5	Bulb Mode & Long exposure	56	11.8	P+ series Technical specifications	113
4.6	Camera display light	56	11.9	End User support Policy	114
4.7	Front/rear dial lock mechanisms	57			
4.8	Self timer mode	58			
4.9	Interval photography	59			
4.10	Depth of field	60			
4.11	Infrared photography	61			

### COMPENDIUM - ADDITIONAL TEXTS

TTL Flash photography on Phase One camera and Focal Plane shutter  
Web resources.

## 1.0 Introduction

### 1.1 Open Platform – Freedom of Choice

Thank you for choosing the Phase One 645DF Camera.

The Phase One 645DF Camera provides you the most powerful digital camera solution whether you are working on location, or tethered in a studio.

With support for what is probably the widest array of focal plane and leaf shutter lenses in the market, the Phase One 645DF camera gives you incredible versatility. Whether you are shooting portrait, landscape, fashion, wedding, product or architectural photography you will always find a solution from Phase One that fits your needs.

For more than 20 years Phase One has been on the cutting edge of research and development to bring you a camera system that provides the absolute best solution to image quality and workflow.

Phase One is committed to not only provide the best digital solution for the professional photographer, but also to ensure the photographer freedom of choice regarding lenses, bodies, back, software, and accessories.

Capture One 5, for Mac OS 10.5.6 and Windows™, is the new generation of software to handle your personal workflow, and is optimized for tethered shooting.

The P+ Series of digital backs have been in the hands and on the sets of world class photographers for years and have become legendary in the field. The entire system comes ready to use in it's own custom weatherproof camera case.

We sincerely hope you will enjoy working with this new and innovative camera platform.



## **1.2 Warranty**

Please read the enclosed warranty certificate. Should any problem occur, please contact your local dealer (place of purchase) to facilitate a repair. – Do not try to repair the camera yourself, unauthorized attempt to repair camera will terminate the warranty.

## **1.3 Recommended hardware**

Capture One 5 may run on older computers, but Phase One recommends following the minimum requirement to ensure the best result from Capture One 5.

### **Apple® Macintosh®:**

Intel based processor

2 GB RAM

10 GB free hard disk space

Calibrated color monitor with at least 1280x800, 24-bit screen resolution

Mac OS X 10.5.6

Mac OS X 10.6

### **Microsoft® Windows®:**

Intel® Pentium® 4 or equivalent

2 GB RAM

10 GB free hard disk space

Calibrated color monitor with at least 1280x800, 24-bit screen resolution

Windows XP®, Service Pack 3 or higher

Windows Vista® Service Pack 1

Windows® 7

Microsoft® .NET Framework 3.5 Service Pack 1 Redistributable package

– In case you do not already have this installed, Capture One will initiate installation of this.

We would recommend upgrading your computer in the areas below if you work with high pixel-count cameras or simply want to optimize performance:

Use processors with multiple cores, e.g. Intel Core™ DUO or better.

Having 4GB RAM or more.

Plenty of hard disk space for your images.

License

**Activate Capture One**  
Please fill out the fields below.

License Code: M73U TTM9 XTRX 4C4U  
Valid license code for Capture One.

Profile

E-mail:

First Name:

Last Name:

Country:

Back Help Activate...

License

**Activate Capture One**  
Please fill out the fields below.

License Code: M73U TTM9 XTRX 4C4U  
Valid license code for Capture One PRO.

Profile

E-mail: newprofile@phaseone.com  
No matching profile found, a new one will be created for you.

First Name: New

Last Name: Profile

Country: United States

Back Help Activate...

License

**Activate Capture One**  
A new profile will be created for you. Please verify the information and create a password for your new profile.

New Profile

E-mail: newprofile@phaseone.com  
First Name: New  
Last Name: Profile  
Country: United States

New Password

Password:

Confirm: Minimum 6 characters

Back Help Activate

## 1.4 Installation and Activation of software

You can only install Capture One 5 when your computer is connected to the internet unless you choose to install Capture One DB (Digital Back) - only supporting Phase One backs.

### Install on Mac OS X 10.5.6 or later:

Capture One software includes an easy-to-use installer that will install all the software necessary to run the application on Mac OS X 10.5.6 or later.

To install the software follow the procedure below:

1. Either load the Capture One DVD, or download the application from the Phase One website: [www.phaseone.com](http://www.phaseone.com).
2. Open the Capture One disk image
3. Read and accept the license agreement presented
4. Drag the Capture One icon to the Applications folder
5. Open Capture One from your Applications folder

### Install on Windows:

Capture One 5 includes an easy-to-use installer that will install all the software you need to run the application on a Windows based computer.

To install the software follow the procedure below:

1. Either load the Capture One DVD, or download the application from the Phase One website: [www.phaseone.com](http://www.phaseone.com).
2. Run the executable software install file.
3. Read and accept the license agreement presented
4. Follow the on-screen instructions to complete the installation.

- In case you do not already have Microsoft® .NET Framework 3.0 installed, Capture One will initiate installation of this.

To activate Capture One 5 you normally need to be connected to the internet. **But installing as Capture One 5 DB “Digital Back only” does not need internet connection.** - An internet connection is needed to do updates.

Your first step towards activating Capture One is to open the license activation dialogue in the application as illustrated.

Open the license activation dialogue via the menu Capture One>License.

Enter your License code and personal details in the license activation dialogue. Enter the Capture One license code you received, either by email or in the original software package, upon purchase.

Type in the personal details that you want, and register your types of hardware along with your software activation. Once you have entered the information press the “Activate License” button and your activation will be validated by Phase One’s activation server. Your software is now activated and ready for use!

### **Troubleshooting**

If you are experiencing problems activating the software, follow the instructions provided in the application, read the software manual enclosed or visit our website for inspiration and troubleshooting: <http://www.phaseone.com/support>

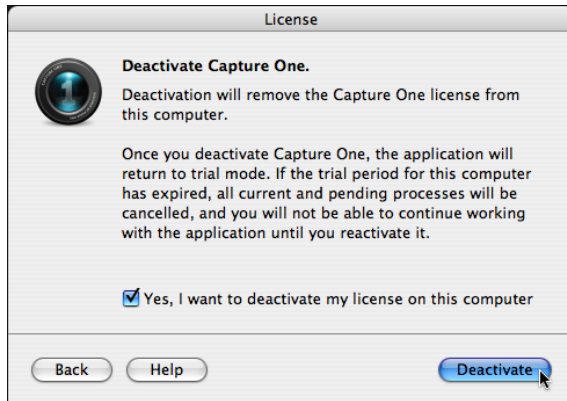

## 1.5 Deactivation of Capture One 5

To deactivate Capture One 5 from a computer you need to be connected to the internet.

Open the license dialogue via the menu Capture One>License.

Press the Deactivate button.

Once you deactivate Capture One, the application will return to trial mode. If the trial period for the computer has expired, all current and pending processing will be cancelled, and you will not be able to continue working with the application until you reactivate it.

Confirm that you want to perform the deactivation. After doing so, you can activate Capture One on another computer.

## **1.6 Screen calibration**

Your monitor is key-element in your daily workflow. Therefore having a properly calibrated monitor is a very importantinadvertent factor when viewing your images.

Just as you would ensure you were viewing your prints and negatives in color neutral light, you would also want to ensure your digital viewing conditions are as accurate as possible.

Consider your monitor the new digital lightbox. To ensure accuracy, monitors need to be hardware calibrated. A quality monitor and calibration tool provides you with a guarantee that what you are seeing on screen is correct. Once a monitor has been calibrated, the color and brightness controls should be locked to prevent inadvertent changes.

Hardware-based monitor calibrators are now available at reasonable prices. The process is simple, quick and enables images to be judged with certainty. Higher level monitors have internal calibrating software that works with professional calibration devices for ultimate accuracy.



## **2.0 The Body - the system**

The Phase One Camera system is created to provide as much flexibility and openness as possible. For years Phase One has offered two different digital back or camera kit options, the the Classic and Value Added, the contents of each are listed below.

### **2.1 Unpacking the 645DF system**

The Phase One 645DF system is delivered in a case created for the travelling photographer, the waterproof and impact resistant case has the standard measurements of carry-on baggage in airplanes.

Open the case by pressing and pulling back the latches on the front/ opening.

#### **Classic:**

waterproof case, as delivered the case will hold:

- Phase One 645DF body
- P+ Digital Back
- Schneider Kreuznach 80mm LS f 2.8 Lens
- Capture One DB
- 1 Year warranty

#### **Accessories**

- Waterproof hard case
- Lens Wrapping
- Digital back battery
- Dual DB battery charger
- 4.5m Firewire cable
- Body and lens caps
- Camera neck strap
- Digiclean kit

**Value Added:**

The case is flexible inside, completely customizable so you can decide the actual content and interior of the case. But as delivered the case will hold:

- P+ digital back
- 645 DF camera body
- Schneider Kreuznach 80mm LS f 2.8 Lens
- Capture One PRO
- 3 year value added warranty with digital back loan unit

**Accessories**

- Waterproof stroller hard case with room for 17" laptop
- Multimount adapter for HB V-lenses
- 2 lens wrappings
- 2 digital back batteries
- Extra camera battery cassette
- Dual DB battery charger
- DB Multi connector cable
- LCC calibration plate
- CF card
- CF card reader
- 4.5m Firewire cable
- QP reference card
- Digiclean kit
- Body and lens caps
- Camera neck strap

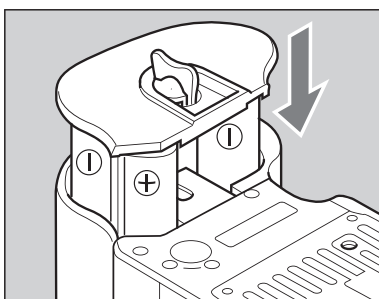
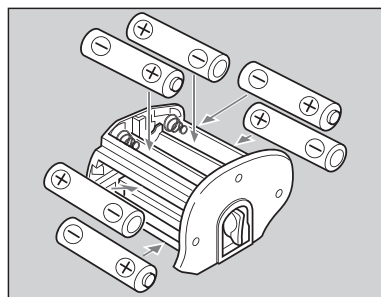
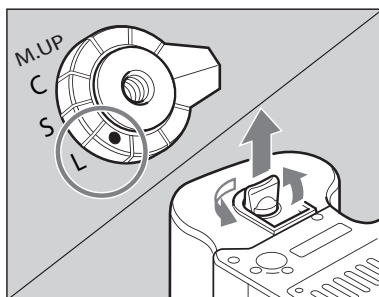

The batteries are sufficiently charged.



There is little power remaining. Have new batteries on hand. Camera will still operate.



There is very little power remaining. Camera will not operate. Set the shutter release mode selector lever to "L" (to turn the power off) and replace the batteries with new ones.



When the batteries are emptied for power, "batt" flashes on the main LCD and the viewfinder's LCD when the shutter release button is pressed.

## 2.2 Batteries for camera

Set the shutter release mode selector lever to "L" (to turn the power off).

Use six "AA" alkaline or Lithium batteries.

NiCd or NiMH batteries should only be used in the camerabody if CF04 is set on rechargeable. [Read more on C-04 Select battery \[batt\] on page 90](#)

1. Lift the battery case lock lever, turn it counter clockwise and pull out the battery holder.

2. Insert fresh batteries with the + and - ends as shown in the drawing.

3. Return the battery holder to its case and lock it by turning the lever clockwise. Make sure it is firmly attached.

- Be sure the batteries are placed with proper polarity.

## Checking the Battery Power

Set the Drive dial lever to "S" (to turn the power on).

Check the battery condition in the lower right corner of the top LCD display.

When replacing the batteries, be sure to use six new batteries of the same type. Do not mix different types of batteries or old batteries with new ones. The camera will not function without any power source.

Never throw out batteries, deliver used batteries for proper disposal.

The camera's power is turned on when the shutter release mode selector is set to "S," "C" or "M.UP." In order to prevent the camera's batteries from discharging, sleep mode is automatically entered if no operations are performed for a specific period of time while the power is ON (with exposure metering status maintained).

In sleep mode, operating the shutter button or a function setting button restores power ON status.

In sleep mode, the external LCD displays is not active, only the marks shown in the figure are displayed. (These marks appear in program AE mode.)

1. Battery life of the originally supplied batteries is dependent on storage conditions.
2. Blots and fingerprints on battery terminals may cause loose connection and corrosion. Wipe them off before loading the batteries.
3. It is advised to carry spare batteries in remote or foreign locations.
4. Battery performance decreases in low temperatures. Keep them warm when in cold climates or locations.  
External battery case PE401 is available as an optional accessory.
5. Store the batteries in a cool and dry place, away from direct sunlight.
6. Remove the batteries from the camera body when they will not be used for a long time.
7. Replace the batteries with new ones as soon as they are exhausted. Liquid leakage from the battery may damage the camera.
8. Read the warnings on the batteries for their handling.

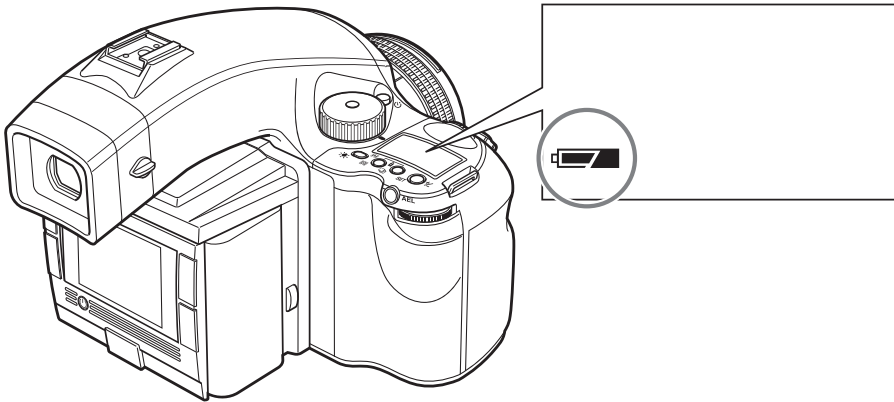

For the purpose of the descriptions and explanations provided in these instructions, it is assumed that the camera's power is on.



### 2.3 Batteries for the back

When the system is unpacked the first thing you should do is give the batteries a full charge.

The Value Added Suitcase comes with two 7.2 volt Lithium-Ion batteries.

Only one battery is used in the P+ back at a time, but it is recommended to charge both batteries fully before you start.

While charging the batteries, you can still use the camera back if you connect it to the IEEE1394/FireWire port on your computer, by using the 6 pin FireWire. - Please note some digital backs cannot be powered from laptop computers.

The charger can adapt to voltages within a range of 110 to 250 volts.

It comes with an international set of source outlet adaptors (placed in the suitcase utility compartment), please select one that fits your outlet, and mount it by sliding it in from the top.

Connect the unit to the outlet and charge the batteries (approximately 2.5 to 3 hours).

**NEVER** throw out batteries. When a battery does not work, deliver the battery for appropriate disposal.

#### Warning!

- Only use the Charger to charge the specified batteries
- Do not allow charger to get wet or get exposed to moisture
- Keep the Charger out of reach of children
- Once charging is completed, unplug the transformer from power source
- Only use the original mains adaptor 12V DC or car lead
- Never apply excessive force when connecting or disconnecting a battery or contact plate.
- Keep all contacts clean.
- Do not force down any of the contacts.
- Do not short-circuit the contacts.
- Never store the battery connected to the charger for an extensive period of time.
- Do not expose to excessive heat or naked flame.
- Do not dismantle or carry out any alteration to the product

#### Purchasing extra batteries

The Phase One P+ back comes with two 2500mAh batteries. If you need to purchase extra batteries Phase One recommend Canon BP 915 2500 mAh.

Due to difference in the tolerances of some third party batteries, these may not fit into the digital back's battery compartment. Do not try to force a battery into the compartment. When pressing the battery release button it should slide in without problems.



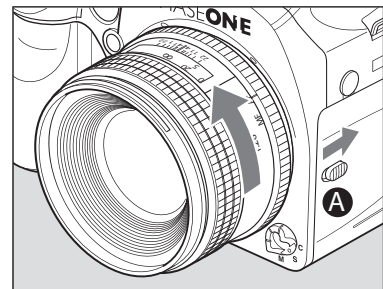
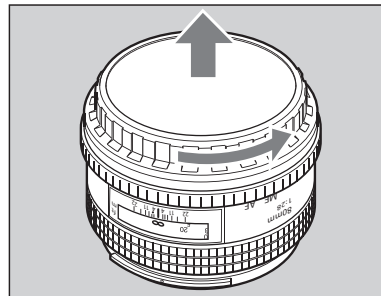
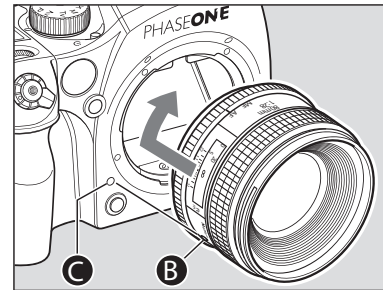
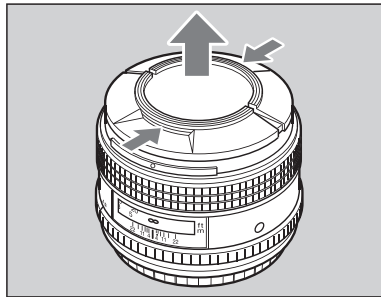
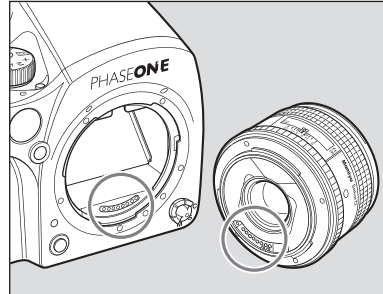
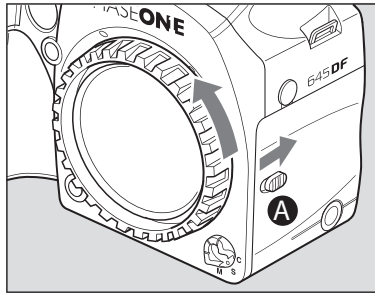

## 2.4 Attach and remove lens

1. Remove the front body cap, just like you would remove a lens, by pushing the lens release button **[A]** backward and then turn the front body cap or the lens itself counter clockwise and lift out.

2. Align the white alignment dot of the lens **[B]** (on the shiny flange) with the camera's white dot **[C]**, mount the lens and rotate it clockwise until it clicks into place.

To remove the front lens cap, squeeze the shiny sections together and lift out.

To remove rear lens cap turn it counterclockwise.

### Removing

While sliding the lens release button **[A]** back, rotate the lens counter clockwise until it stops, and lift it off.

After removing the lens from the camera body, protect both ends by attaching the caps.

Oil, dust, fingerprints, or water on the electronic contacts could result in malfunction or corrosion. Wipe such impurities off with a clean piece of cloth.

Do not touch the distance ring or other rotating parts when attaching the lens. When installing a lens, do not press the lens release button.

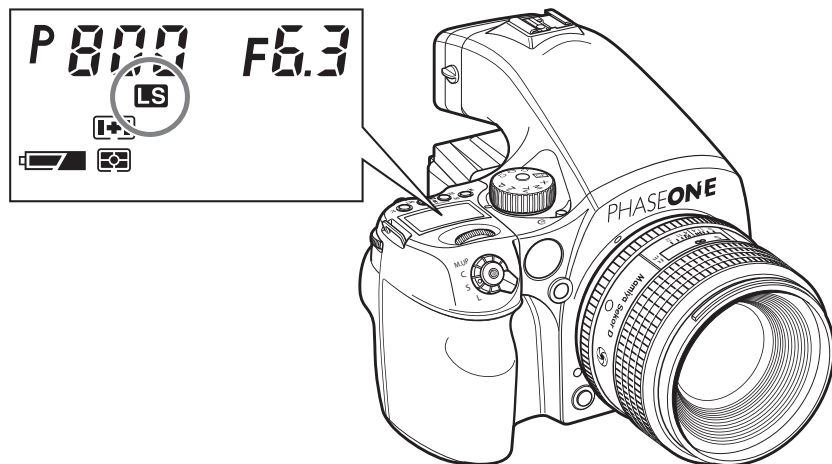

### Attach the leaf shutter lens

Leaf shutter lenses are equipped with an internal shutter, leaf shutter lenses are capable of high shutter speeds 1/800 sec. or 1/1600 on P65+ and P40+ with flash synchronization which is particularly useful when you are doing daytime fill-in flash photography.

When the leaf shutter lens is attached and the leafshutter is used, the letters “LS” will appear in the main LCD display.

#### Notice:

When using settings “P” (Program AE), “Av”(Aperture priority AE) or “Tv” (Shutter priority AE), it is possible to control the preferred type of shutter or the “Auto” mode and C-17.

[Read more on C-17 Choose shutter function Program mode \[Sh\\_P\] on page 91](#)

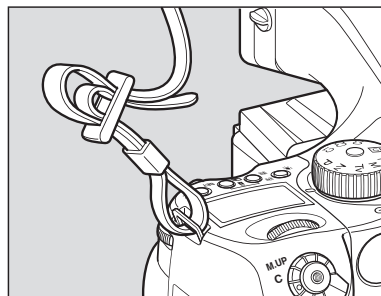

### 2.5 Adjusting the Strap

Put the neck strap through the mounts and secure it to the buckle as illustrated.

After attaching the strap, pull it and make sure it does not loosen at the buckle.

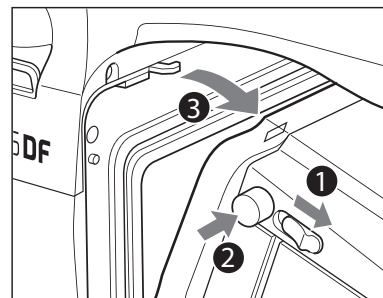
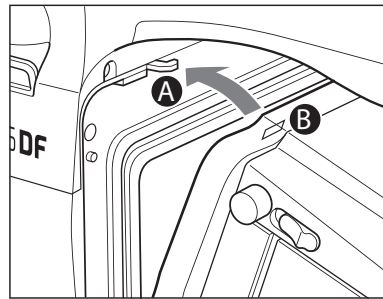
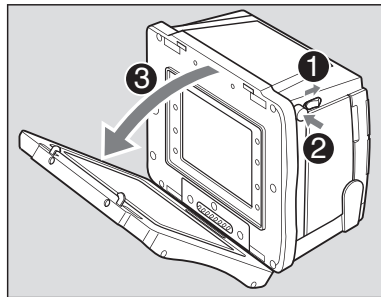
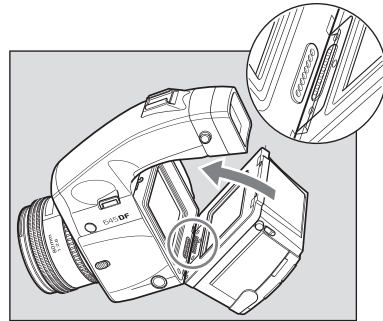
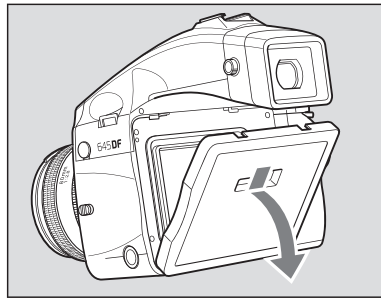

## 2.6 Attaching the back

The P+ back is fully integrated with the camera body and functions as a part of the whole camera system.

When no digital back attached to the Phase One 645DF camera body the mirror is up and the shutter is open. This is the correct position when no back is attached.

When attaching the P+ back to the camera body the shutter will close and the mirror come down.

First remove the cover, it is important to ensure that the bottom part of the P+ back is placed correctly in the lower locking mechanism on the back of the camera body before the upper locking mechanism **[A+B]** is pressed together.

Failure to do this can cause an error with the camera body. where the shutter will continuously open and close. If this occurs, remove the P+ back. Make sure the camera body is powered, press button **[2]** while mounting the digital back, lock the mounted back by pressing **[1]**

Please be aware that the shutter should be in the correct starting position (shutter open), if this is not the case, attach and remove the P+ back again to make sure that the camera body gets in the correct starting position.

Remove the P+ back by pushing back lever **[1]**, push in button **[2]**, and gently pull away top first, be careful on the contacts and protective glass on the back, your back should always be protected by the protection plate, when not attached to the camera.

## 2.7 The parts of the camera system

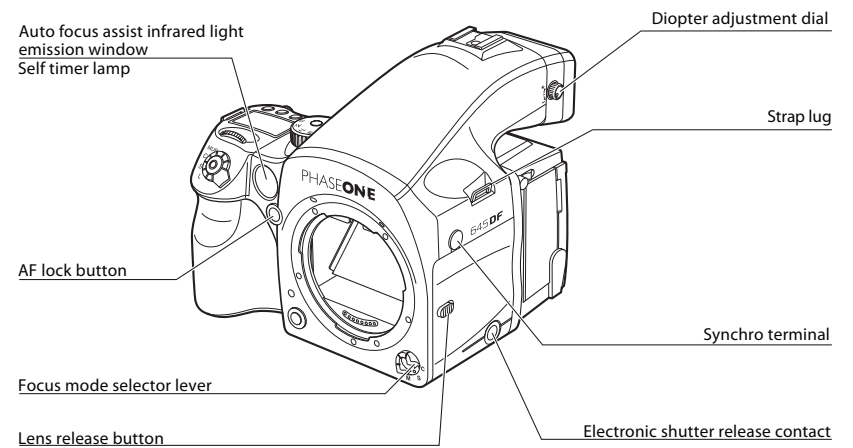
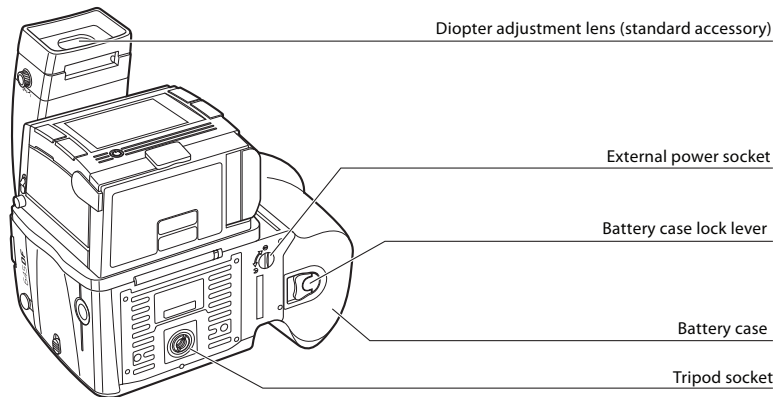
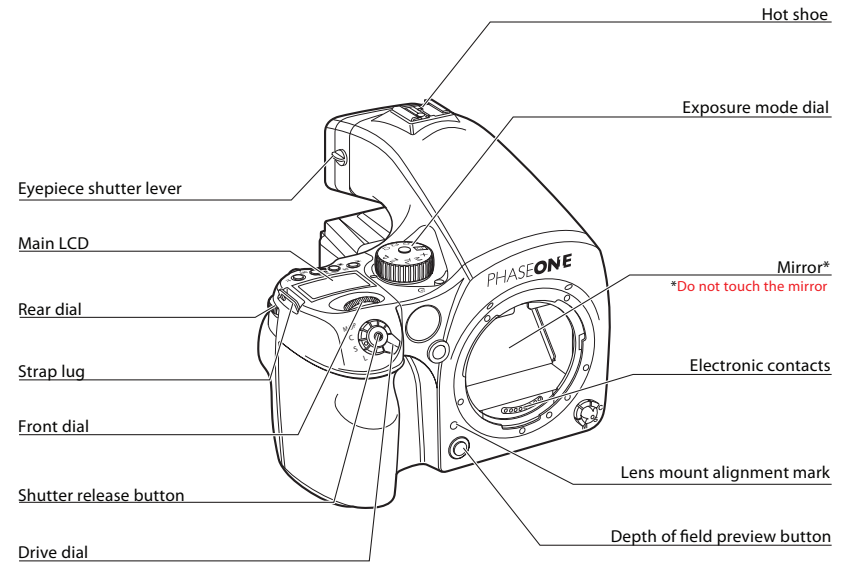
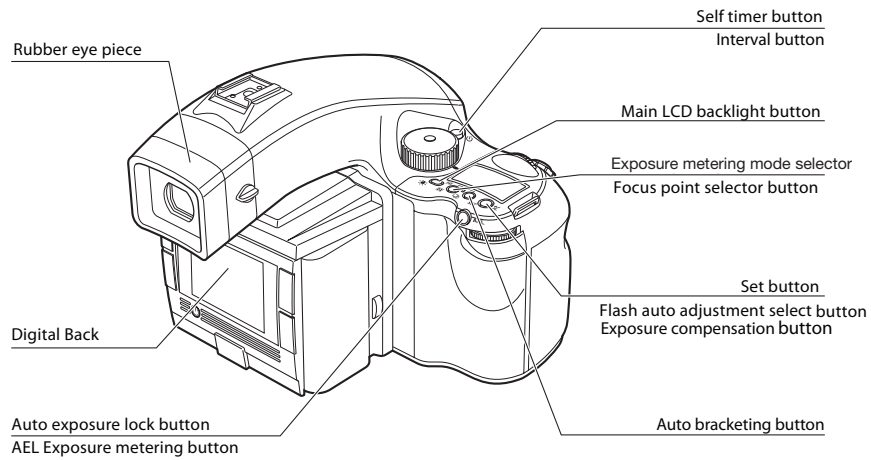

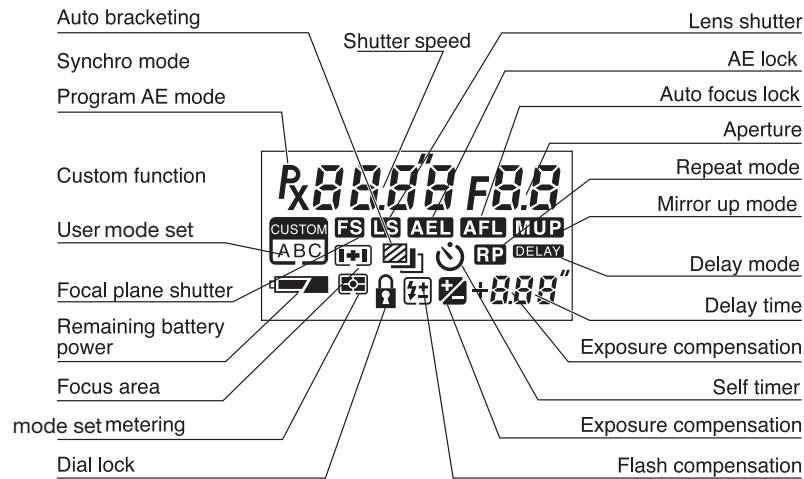

During actual use, only the relevant icons and indicators are displayed.

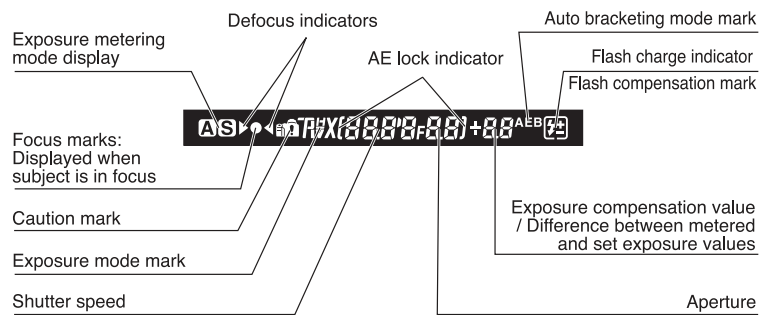

During actual use, only the relevant icons and indicators are displayed.

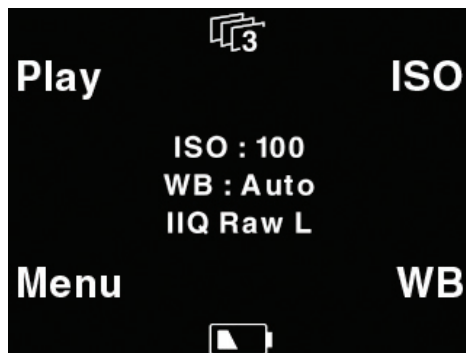

## 2.8 The displays

The display on the camera body will provide you with a lot of valuable information. This includes many features and settings including, but not limited to shutter speed, aperture value, exposure program, exposure compensations and metering modes. See the figure for full explanation.

### Viewfinder display

The most relevant information regarding the capture can be read on the bottom display in the viewfinder along with the autofocus mark indicating that the focus is correct.

### Back display

The display on the back is a multifunctional display, where the menus change depending on the status and choices you make.

In addition to providing menu navigation, the display on the back can work as preview screen.



## 2.8 Display abbreviations

### Liquid Crystal Display

Due to the limitations of the space and letters, words and letters on the LCD are abbreviated.

Display examples of the main LCD

<i>On</i>	→	ON
<i>Off</i>	→	OFF
<i>Err</i>	→	Error
<i>+</i>	→	+ (Plus)
<i>u</i>	→	Under
<i>o</i>	→	Over
<i>n</i>	→	Normal
<i>Loc</i>	→	Lock
<i>SELF</i>	→	Self Timer
<i>bulb</i>	→	bulb
<i>buSy</i>	→	Busy
<i>db</i>	→	Digital Back
<i>LS</i>	→	Lens Shutter
<i>CAP</i>	→	Capture
<i>rP</i>	→	Repeat
<i>TIME</i>	→	Time

Display examples in the custom function mode

<i>SEL</i>	→	Selection
<i>STEP</i>	→	Step
<i>IRIS</i>	→	Iris
<i>Hold</i>	→	Hold
<i>batt</i>	→	battery
<i>Shot</i>	→	Shot No.
<i>dF</i>	→	Dial function
<i>d.AC</i>	→	Dial action
<i>d.di</i>	→	Dial direction
<i>REFL</i>	→	AE, AF lock
<i>HALF</i>	→	Half press
<i>REL</i>	→	AE lock
<i>RFL</i>	→	AF lock
<i>OnEP</i>	→	One-push exposure
<i>RF.L</i>	→	AF assist light
<i>FLSY</i>	→	Flash sync
<i>bu</i>	→	Buzzer
<i>Sh.P</i>	→	Shutter in Program
<i>Sh</i>	→	Shutter in Manual
<i>RF.2</i>	→	AF second mode

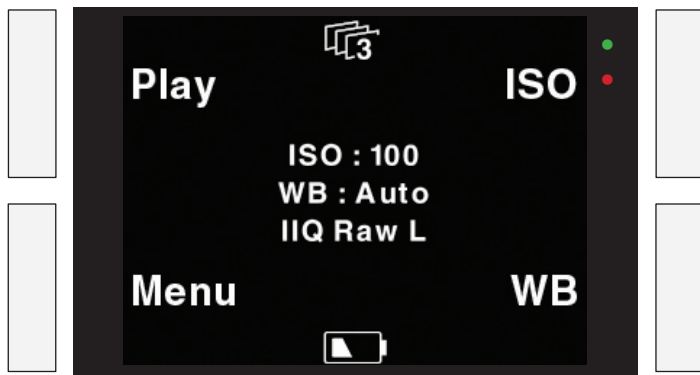

## 2.9 The buttons on the back

The back is equipped with four buttons, these buttons will take you through all functions of the back, and the buttons will change function to match the menu shown on the display. Read more on the menus in the chapter regarding this.

## 2.10 LED lights

When the camera is powered up you will see a short blink in the green and red LED's in the right hand side of the display and you will hear a ready beep. The lights will turn off immediately. This is an indication that the camera is ready to capture.

Green: When capturing an image the green LED is blinking rapidly to indicate that the P+ back is busy.

Steady green light indicates that the backlight of the display is dimmed but the camera is still ready to shoot.

(The time before this happens can be set in the P+ back and is described later under "Menu mode")

RED: If the red LED is on this indicates that the P+ back is writing to the storage media therefore the buffer is not emptied.

The red LED indicator located just beside the CF-cardslot under the cover in the left side is assigned to only indicate CF card activity.

When the red CF-slot LED is on, do not remove the card from the card slot! This can damage the formatting of the card, and images or data might be lost or corrupted.

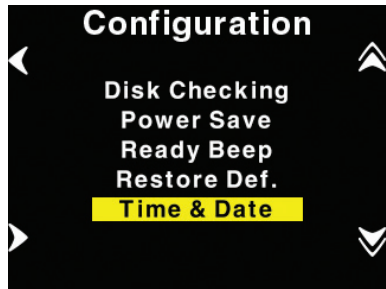

## 2.11 Setting date and time

Date and time is set and controlled through the digital back.

Default date and time is GMT+1.

If the digital back has been without power for a longer period of time, it will automatically ask you to setup time and date when it is powered up.

In the "Time & Date" menu you can set the time and date using the four buttons on the P+ back. Left side buttons will step through the hours, minutes and seconds field, while the right up and down buttons can be used to set the value of the fields.

The time and date is applied to all files captured with the P+ back.

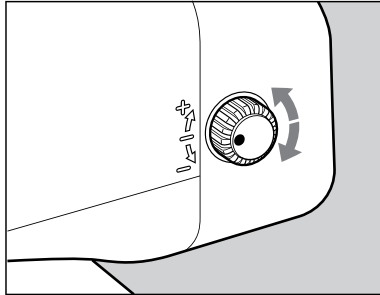

Diopter correction lens	Range of Adjustment
DE401 (standard)	-2,5 to +2,5
DE402 (farsighted users)	-5,0 to -2,0
DE403 (farsighted users)	0 to +3,0

## 2.12 Setting diopter

Look through the viewfinder and make sure that the focus frame (Rectangle with Circle) is in sharp focus. If it is not, turn the diopter adjustment dial in the “-” direction if you are nearsighted, in the “+” direction if you are farsighted. If this is not sufficient you may require an optional diopter correction lens. check the table for possible diopters.

Point the camera at a bright, plain object such as a white wall when making this adjustment.

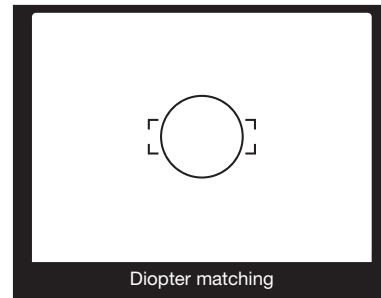
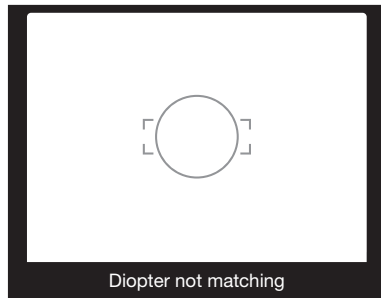

**Notice:**

If there is dirt or dust on the lens surface, remove it with a blower or sweep it off gently with a lens brush

If there are fingerprints or dirt on the lens surface, wipe them off with a piece of clean, soft gauze

Using solvents could discolor the discolor correction lens frame

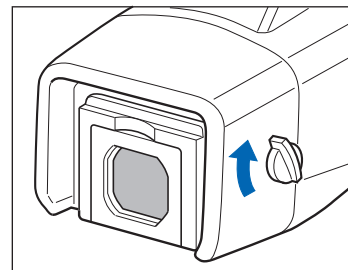
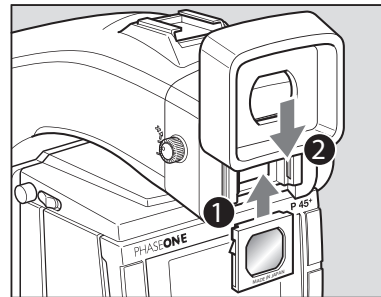
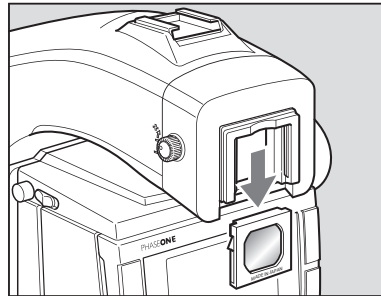
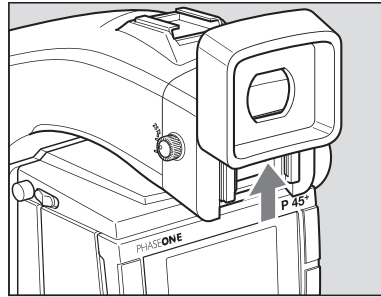

**Replacing the Diopter Correction Lens**

1. Remove the rubber eye piece by sliding upwards

2. Remove the lens supplied with the finder by pulling it downward.

3. Remove the existing diopter by sliding downwards using the fingernail groove and detach. Insert a new diopter by aligning it to the base of the diopter holder and sliding it upwards into place then reattach the rubber eyecup.

**2.12 Eyepiece shutter**

Close the eyepiece shutter when there is a strong light source behind the camera or when pressing the shutter release button without looking through the viewfinder.

(This prevents exposure error due to light entering from the viewfinder.)

Turn the eyepiece shutter lever in the direction of the arrow.





### 3.0 Basic functions

#### 3.1 Setting ISO

ISO functionality is controlled by the digital back.

The default ISO setting is either ISO 50 or 100 depending on which back you are using. Keep in mind that the higher ISO you are using, the higher degree of noise you will see in your image file. This is why Capture One and the camera system is holding a powerful noise reduction methods as well as the Sensor+ technology on certain digital backs, however it is possible you will still see some noise.

On your digital back from the main menu, push the top left button next to “ISO”, this will bring you to your ISO choices, scroll up and down and press “enter” to select the desired ISO. If you are shooting tethered, you can also use the Capture tool tab in Capture One for ISO selection.

#### ISO and White Balance

When the display is in its home position, the two buttons to the right, ISO and WB brings you directly to the ISO and White balance settings, where you can scroll up and down, and select the setting you want with the “Enter” button. Also White Balance can be controlled by Capture One if you are working tethered.

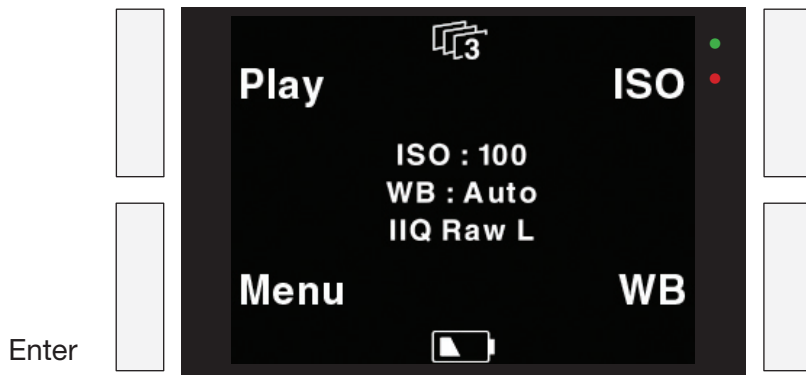

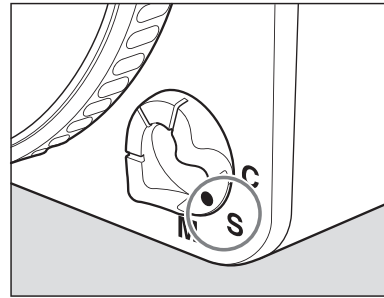
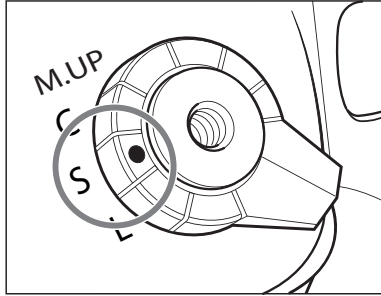

### 3.2 Easy Photography

1. Set the shutter release mode selector lever to “S” (single-frame advance mode).

There are two shutter release modes: “S” (singleframe advance mode) and “C” (continuous advance mode).  
When set to “L” the power is turned off.

2. Set the focus mode selector lever to “S” (single focus mode).

There are three focus modes: “S” (single focus mode), “C” (continuous focus mode) and “M” (manual focus mode).

3. Set the exposure mode selector dial to “P” (program auto exposure).

Focus Mode		Focusing
S	Single focus mode	Half-press the shutter release button to focus. When the focus mark lights, the focus is fixed and the shutter can be released.
C	Continuous focus mode	The camera keeps focusing continuously while the shutter release button is half-pressed. The shutter can be released regardless of whether or not the focus mark is lit.
M	Manual focus mode	Focus manually.

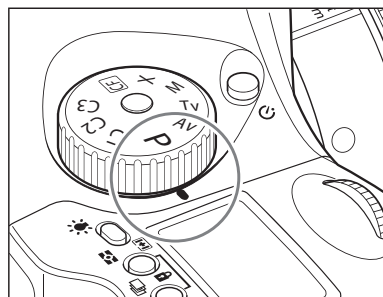

**There are four exposure modes:**

“**P**” (Program Auto Exposure),

“**Av**” (Aperture priority AE)

“**Tv**” (Shutter priority AE)

“**M**” (Manual mode).

**P:** Program AE - The aperture and shutter speed are determined automatically according to the shooting conditions. This mode is best suited for general photography, since it allows you to concentrate on the shooting. You can change the shutter speed and aperture by turning the front and rear dials while the “**P**” (Program AE) mode is selected.

**Av:** Aperture priority AE - Set the desired aperture and the camera selects the correct shutter speed. Use this mode to control depth of field.

**Tv:** Shutter priority AE - Set the desired shutter speed and the camera selects the correct aperture. Use this mode to stop motion.

**M:** Manual mode - Set this mode when you want to use special combinations of the aperture and shutter speed.



4. Exposure metering mode is automatically set to average/spot exposure metering before exposure metering is performed.

There are three exposure metering modes: In the “**A**” mode the average brightness in the entire frame is measured with emphasis on the center of the frame. The brightness at a specific spot in the center of the frame is metered in the “**S**” mode. The “**A-S**” mode automatically switches between these two modes depending on the contrasts in the picture.

**NOTE:**

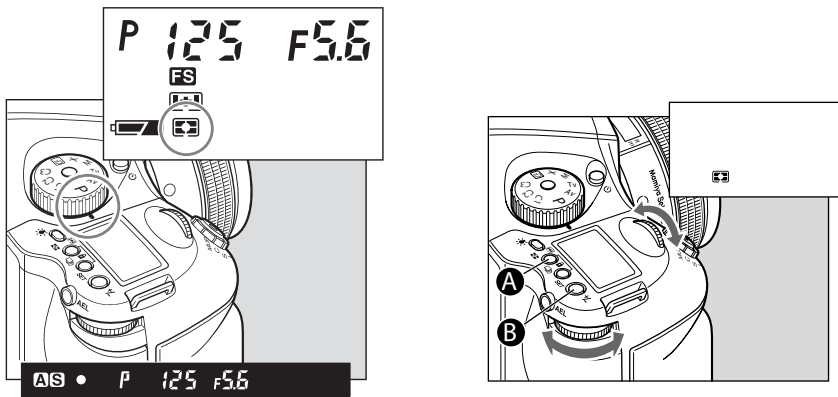
When a polarizing filter is used, ensure that a circular polarizing filter(C-PL) is used. The correct exposure cannot be obtained with a normal(linear) polarizing filter (PL).



<p>Average/spot auto exposure metering</p> 	<p>Exposure metering is performed after automatically selecting average/spot exposure metering. • Depending on the subject conditions, center-weighted average/spot exposure metering is selected automatically, and the correct exposure is measured.</p> <ul style="list-style-type: none"> <li>• Spot exposure metering is automatically selected when the brightness of the spot exposure metering range becomes darker than the brightness of the entire screen.</li> <li>• If there is very little difference between the spot exposure metering value and center-weighted average exposure metering value, the correct exposure level is obtained as the intermediate value.</li> </ul>
<p>Center-weighted average/spot exposure metering</p> 	<p>The average brightness of the entire screen is measured, emphasizing the center of the screen.</p>
<p>Center spot exposure metering</p> 	<p>The brightness of an area equivalent to 7.6% at screen center is measured, and the exposure is determined. The circle at screen center serves as a general guideline. This mode is suited to measuring subjects with strong contrasts or measuring only screen portions.</p>

Viewer display →



**NOTE:**

The “time to sleep function” can be changed. Read more on C-03 Time to sleep [HOLD] on page 90

### 3.3 Measuring light – Exposure Metering

1. Exposure metering mode mark is displayed when the exposure metering mode button [A] is pressed shortly. Three different exposure metering modes are displayed sequentially when either the front or rear dial is turned, select an appropriate exposure mode.
2. Press the SET button [B] or exposure metering mode button [A] to enter the setting.

### Exposure Warnings

With an inappropriate exposure setting, when shooting subjects that are too bright or too dark, the user is warned by the flashing external LCD or the LCD inside the viewfinder.

At such times, the correct exposure cannot be obtained.

Warnings that the exposure is outside the metering range

- Program AE (P)  
The shutter speed and f-number blink.
- Aperture priority AE (Av)  
The shutter speed blinks.
- Shutter priority AE (Tv)  
The f-number blinks.
- Manual mode (M)  
The exposure metering value difference is displayed.

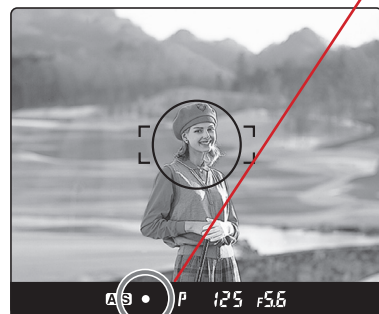
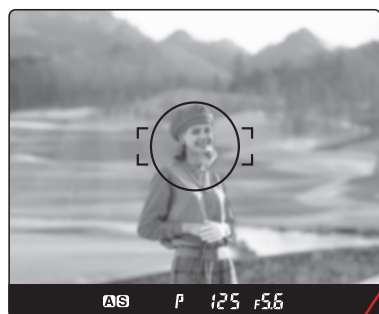
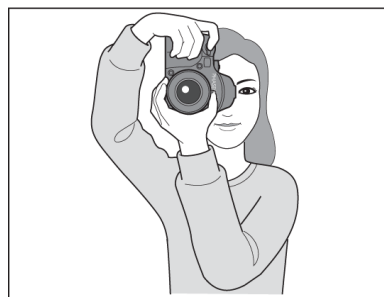
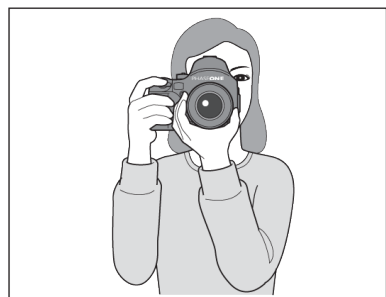
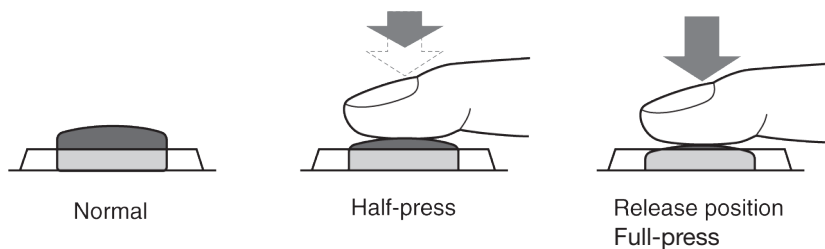

### 3.4 Focus modes

If autofocus AF is desired, chose AF on the focusing selector ring on the lens, then chose between S(single) and C(continuously) Auto focusing. The Focus selection ring on the lens will help you to rapidly switch between AF and M, without having to change your grip of the camera.

The shutter release button has a two-step action. When pressed lightly it stops at a certain point. In this manual this position is called the “half-press” position. When you “half-press” this button, the camera functions are activated. When the shutter button is pressed further down, the shutter is released. This position is called the “full-press” position.

1. Aim the camera so that the subject is within the focus frame.
2. Half-press the shutter release button, and focus will be adjusted automatically when you are using auto focus. As default you can now re-compose your image without loosng the original focus setting, by moving the camera and keeping the shutter release button half-pressed.

When the focus mark • lights up, the subject is in focus.

3. When the focus mark • lights up, press the shutter release button further down to release the shutter.

#### Out of focus Marks ▶ ◀

When the picture is not focused the shutter cannot be released, when in single focus mode. Either press the shutter release button again to adjust the focus or move the camera to change the position of the focus frame.

While the camera is operated in auto focus mode, lenses without the focus mode selector ring will automatically be in auto focus. Do not touch the focus ring as you may cause internal damage to the camera auto focus motor.

#### Lenses with the focus mode selector

When a lens with the focus mode selector is attached and the focus mode selector lever of the camera body is set to “S” or “C”, you can change focus modes between automatic and manual with the selector of the lens.

To use the auto focus function, both the camera body and the lens have to be set in the auto focus mode.

When either the camera body or the lens is set in the manual focus mode, auto focus does not function.

See the instruction manual for each lens for the way to switch focus mode on the lens.

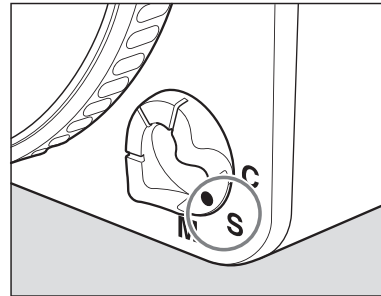

### Single focus mode (S)

This mode uses the focus-priority mechanism. The shutter can be released when the focus mark • in the viewfinder is lit. This mode is suited for still subjects. Focus is locked when the focus mark • lights in the viewfinder's LCD.

The shutter cannot be released if the subject is not in focus (if the focus mark • does not light).

To take another photo with a different composition, take your finger off the shutter release button then re-press the shutter release button again.

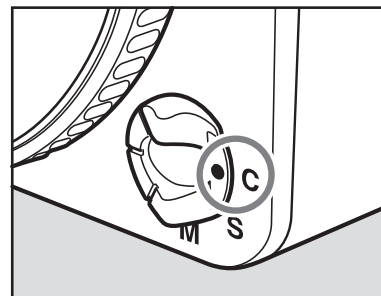

### Continuous focus mode (C)

In this mode shutter release has priority to focusing. The shutter can be released regardless of whether the focus mark • in the viewfinder's LCD is lit. Focus is adjusted continuously while the shutter release button is half-pressed. This mode is suited for moving subjects.

Focus is not locked even if the focus mark is lit.

The shutter can be released even if the focus mark is not lit.

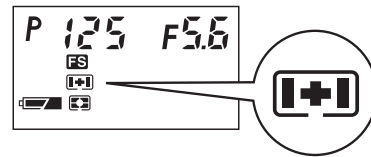
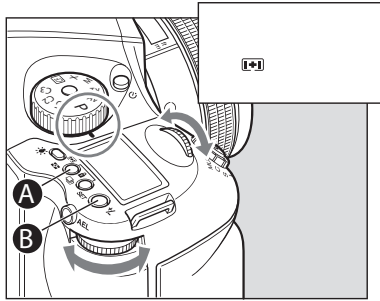

Focus point selection mark

### Multi area focus

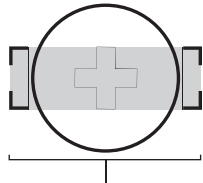

Inside the view-finder

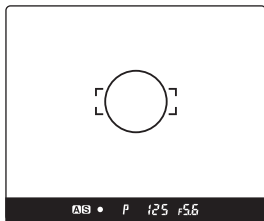

### Spot focus area

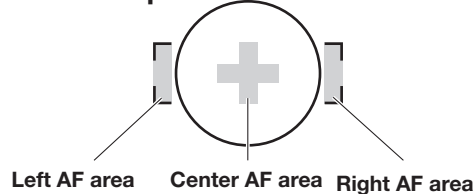

## Focus Areas

You can select the focus area that best suits the kind of pictures you intend to take. Push and hold the Focus selection button **[A]** for at least one second; then turn the front or rear dial to select the appropriate focus area. The selected focus area can be seen on the main LCD panel. When the preferred focus area is selected, press the SET **[B]** button or the focus point selector button **[A]** to exit the setting.

### Multi area focus

When selecting multi area focus, the focus points is positioned in the viewfinder according to the illustration shown to the right. If multiple objects is located within the focus frame, the camera will lock on to the object closest to the camera.

### Spot focus area

When spot focus is selected, the camera will lock on to objects positioned in the center of the view finder. The camera will focus on the center mark in the focus frame **[O]** in the viewfinder.

## Manual Focus Mode (M)

In case you want to have full manual control of the focus function you can change to manual focus mode in two ways.

### 1. All lenses .

Turn the focus mode selector lever to "M" (manual focus mode).

### 2. Manual Focus operation for Telephoto and Zoom lenses.

All newer Phase One, Mamiya and Schneider Kreuznach lenses can be switched from Auto Focus to Manual Focus by using the AF ring or slider fitted on the lens.

For lenses with AF slider, slide the focusing ring on the lens backward until it clicks. When this is done, the "Auto Focus" inscription on the lens barrel is covered and the lens can then be focused manually.

For lenses with an AF ring just turn the AF ring to the MF position to select manual focus.

### Adjust the focus.

Turn the lens focusing ring until the subject is in focus. When correct focus has been achieved, the focusmark in the viewfinder will light up.

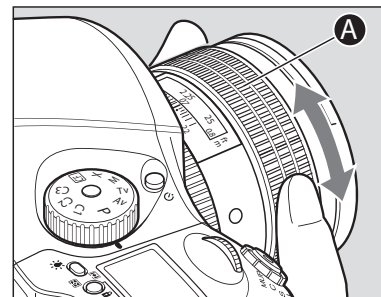
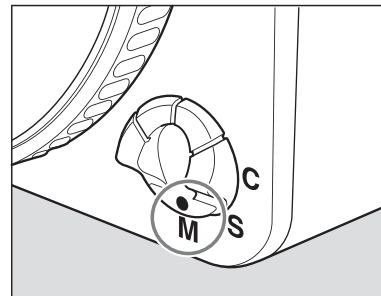



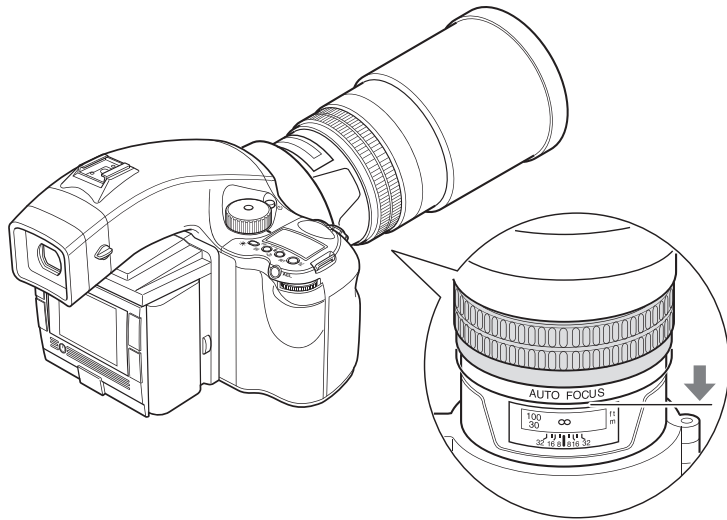

- When a lens with the focus mode selector is attached and the focus mode selector lever of the camera body is set at “S” or “C”, you can change focus modes between automatic and manual with the selector of the lens.

- To use the auto focus function, both the camera body and the lens have to be set in the auto focus mode.

- When either the camera body or the lens is set in the manual focus mode, auto focus does not function.

- See the instruction manual for each lens for the way to switch focus modes on the lens.

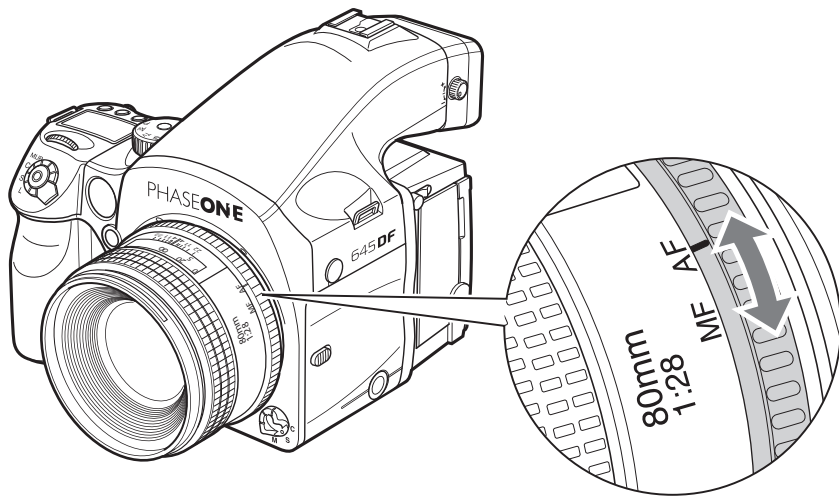

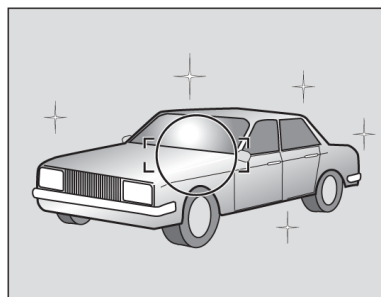
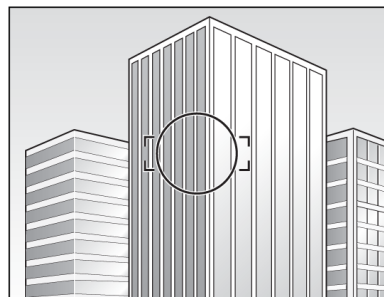
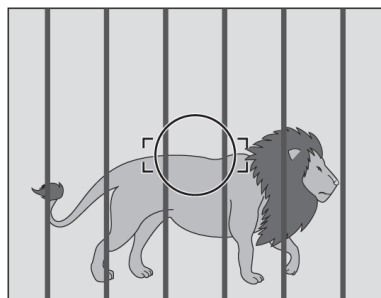
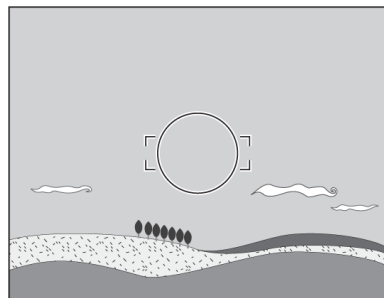

**Manual focusing using the focus mark** (Focus confirmation method)  
 With this camera, the focus mark lights in the viewfinder's LCD when the picture is in focus. With the shutter release button half-pressed, turn the lens focusing ring to focus on the subject. When the subject is in focus, the focus mark lights in the viewfinder's LCD.

If ▶ is lit in the viewfinder's LCD, the camera is focused on a point behind the object.

If ◀ is lit, the camera is focused on a point in front of the object.

- Use the focus mark when taking photos in manual focus mode or using the M645 manual lens.

- If you adjust focus using the focus mark with an M645 lens, make sure to open the aperture. You can use this function with a lens of f/5.6 aperture or higher.

### When Auto Focus Fails

The auto focus function requires contrast on subject. Auto focusing may fail to achieve focus with certain subjects described below. In such cases, either switch to the manual focus mode and focus manually or focus on a more contrast appropriate object at the same distance as the object you want to photograph, lock the focus using the focus lock button on the front of the camera body, then take a picture.

- Low-contrast subject (blue skies, white walls and other objects)
- Two or more objects overlapping at different distances within the focus frame (animals in cages, etc.)
- Subjects with continuous repeated patterns (building exteriors, blinds, etc.)
- Extremely backlit reflective subjects (car bodies, water surfaces, etc.)
- Or when the subject is far smaller than the focus frame

### 3.5 Using focus lock and infrared focusing

#### Using the Focus Lock Function

If the object that you want to focus on is not in the focus frame, the camera focuses on the background at the center. In such cases use the focus lock function to lock the focus before releasing the shutter.

#### 1. Set the focus mode selector lever to “S” or “C.”

Put the subject in the focus frame and halfpress the shutter release button.

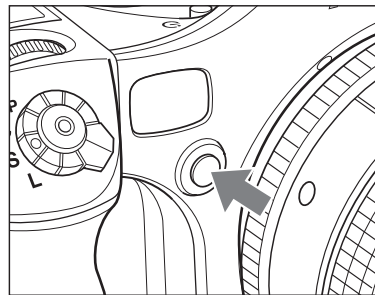
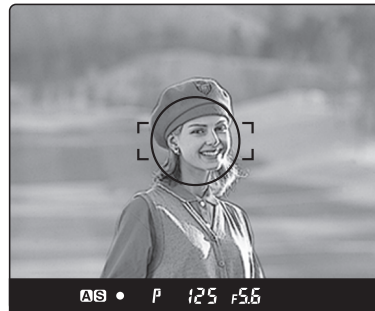

#### 2. Lock the focus.

When the focus mark • in the viewfinder LCD is lit, press the AF lock button on the front of the camera to lock the focus.

#### 3. Adjust the composition.

With the shutter release button half-pressed, slide the camera to achieve the desired composition, and release the shutter.

When the focus mode is set at “S” (single focus mode) and the focus mark • is lit, hold the shutter release button halfway down to lock the focus.

#### NOTE

Assignment of the AEL and AFL buttons can be swapped.

[Read more: C-09 AEL & AFL function button exchange \[AEFL\]](#)

- You can set the camera so that when the AFL button is pressed, AF is activated and AF lock is performed [Read more: C-12 AFL lock mode setting \[AFL\]](#)

## AF Assist Infrared Light

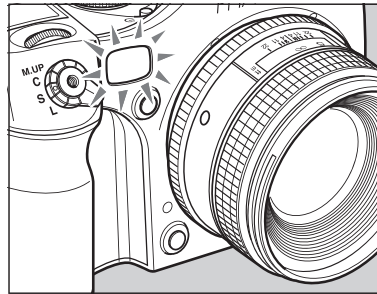

When the subject is dark or very low-key and the camera can fail to auto-focus, a red lamp may light on the front of the camera when the shutter release button is half-pressed. This light assists the camera's auto focus function and the AF assist infrared light is emitted only when the focus mode is set to "S" (single focus mode)..

### Notice:

Effective range of the AF assist infrared light is limited. It does not reach distant subjects. - Range: 9m/29.5 ft. (using 80 mm f/2.8 lens)

When using a lens hood or a bellows lens hood (sold as an optional accessory) that may interfere the assist light, set focus before mounting the hood.

The AF assist infrared light can be disabled. [Read more: C-14 AF beam setting \[AF\\_L\]](#)

### 3.6 Shutter release modes

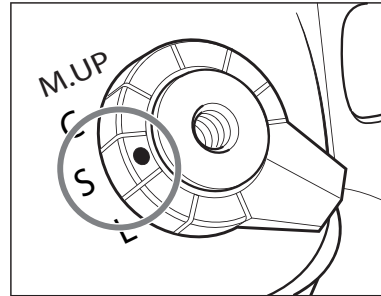

#### Single-Frame Mode

One photo is taken each time the shutter release button is pressed.

Set the shutter release mode selector to “S”

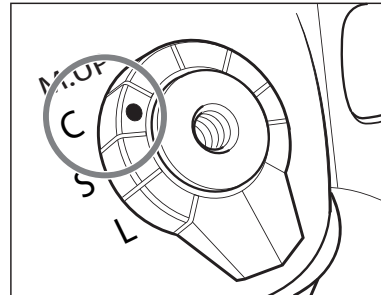

#### Continuous Mode

Photos are taken as long as the shutter release button is pressed.

Set the shutter release mode selector lever to “C”. Photos are taken continuously at a rate depending on the buffer speed of the back mounted on the camera.

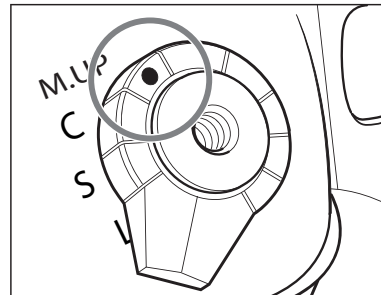

#### Mirror up mode

When the shutter button is pressed, the mirror moves up, and when the shutter button is pressed again, the shutter is tripped, and a picture is taken.

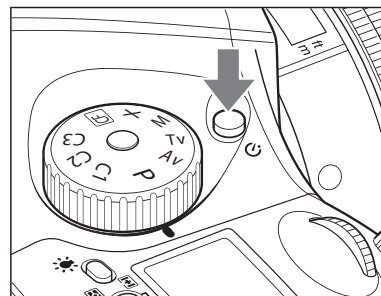

#### Self-Timer Mode

In this mode, the shutter will be released 10 seconds after the shutter release button is pressed.

Turn the shutter release mode selector lever to the ☺ position.

When the shutter release is pressed, the self timer lamp will blink for 7 seconds. Then, it will blink more rapidly for 3 seconds and the camera releases the shutter.

[Read more: 4.8](#)    [Self timer mode](#)

### NOTICE:

If a correct exposure cannot be obtained, the shutter speed and aperture value blink. In such cases, the pictures can be taken but they may turn out too bright or too dark.

If the shutter speed and aperture values blink on the main LCD and in the viewfinder display when the program line is shifted, the proper exposure cannot be achieved. Please select a different Program mode.

When the Program line is shifted, the aperture value changes along with the shutter speed to maintain the proper exposure.

Increment of the aperture and shutter speed can be set at either 1/3 or 1/2-stop. Read more: C-01 Steps of aperture, shutter speed, exposure compensation. [STEP]

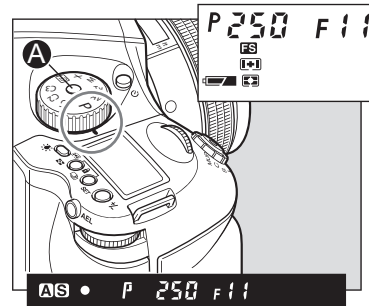

## 3.7 Exposure Modes

### (P) Program AE

The aperture and shutter speed are determined automatically for the optimum exposure, according to the existing ambient light. This mode is best suited for general photography, allowing the user freedom to concentrate on the subject.

Release the exposure mode dial by pressing [A]. Turn the exposure mode setting dial to “P” (program AE) position.

### Program Shift (PH/PL)

You can change the shutter speed and aperture value by turning the front and rear dial in the “P” (Program AE) mode. In order to avoid blurred images (due to shaking while releasing the shutter), or to open the aperture, change to “PH” (high speed). For slower shutter speeds and wider depth of field, change to “PL” (low speed). This function allows you to make these changes quickly.

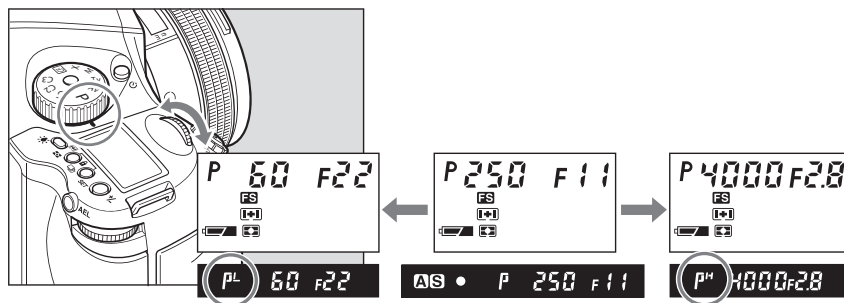

Phase One 645 program shift chart

(ISO100/AF80mm F2.8 D)

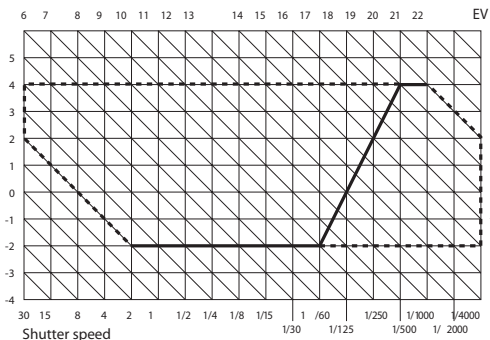

— Normal  
- - - Program shift area

### NOTICE:

The shutter speed value will blink when the subject is too dark or too bright for a correct exposure. To obtain the correct aperture, adjust the aperture value until the shutter speed value stops blinking and remains lit.

When the exposure is compensated with the rear dial, the aperture can be set with the front dial only.

Increment of the aperture can be set at either 1/3 or 1/2-stop. [Read more: C-01 Steps of aperture, shutter speed, exposure compensation. \[StEP\]](#)

Rotation direction of the dials to change the values can be altered. [Read more: C-08 Direction of dials \[d\\_dli\]](#)

The selected aperture level can be locked.

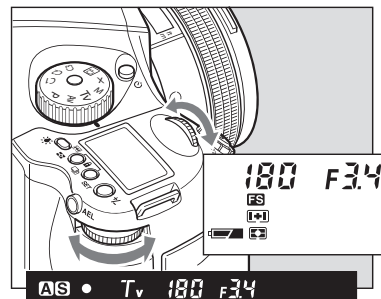
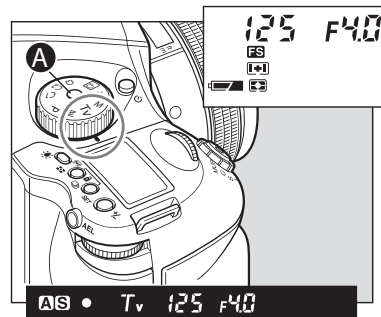
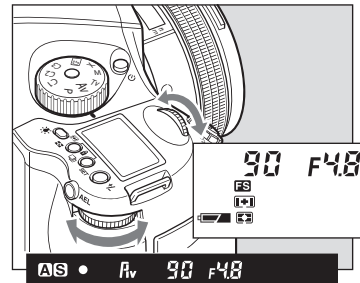
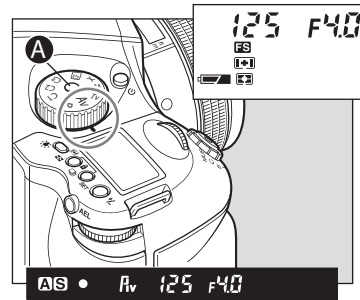

### NOTICE:

The aperture value will blink when the subject is too dark or too bright for a correct exposure. To obtain the correct aperture, adjust the shutter speed value until the aperture value stops blinking and remains lit.

When the exposure is compensated with the rear dial, the shutter speed can be set with the front dial only.

Increment of the shutter speed can be set at either 1/3 or 1/2-stop. [C-01 Steps of aperture, shutter speed, exposure compensation. \[StEP\]](#)

Rotation direction of the dials to change the values can be altered. [C-08 Direction of dials \[d\\_dli\]](#)

The selected shutter speed can be locked.

## Aperture Priority AE (Av)

Set the desired aperture, and the camera selects the optimum shutter speed accordingly. Use the Av mode to maintain specific control over depth of field, i.e. taking portraits or landscapes.

1. Turn the exposure mode setting dial to “Av” (aperture-priority AE) position.

2. Turn the front or rear dial to set the desired aperture.

- If the needed shutterspeed is above 1/800 sec. you can not use the leafshutter, then change to foal plane shutter. [Read more: C-17 Choose shutter function Program mode \[Sh\\_P\]](#)

## Shutter Priority AE (Tv)

Set the desired shutter speed and the camera selects the optimum aperture accordingly. Fast shutter speed can be used to freeze motion, and slow shutter speed can be used to blur motion on purpose.

1. Turn the exposure mode setting dial to “Av” (aperture-priority AE) position.

2. Turn the front or rear dial to set the desired shutter speed.

- If the desired shutterspeed is above 1/800 sec. you can not use the leafshutter, then change to foal plane shutter. [Read more: C-17 Choose shutter function Program mode \[Sh\\_P\]](#)



### NOTICE:

When the exposure is compensated in the Manual mode, the difference between the metered value and the compensated value will be displayed on the viewfinder LCD. In the B (Bulb) mode, the difference with the metered value is not displayed.

Increment of the aperture and shutter speed value can be set at either 1/3 or 1/2-stop. C-01 Steps of aperture, shutter speed, exposure compensation. [STEP]

The assignments of the front and rear dials can be swapped. C-06 Front/Rear dial function exchange in manual mode [dF]

Rotation direction of the dials to change the values can be altered. C-08 Direction of dials [d\_dli]

The selected aperture and shutter speed can be locked.

### Notice:

When the set value matches with the metered value, the difference indicator will show "0.0".

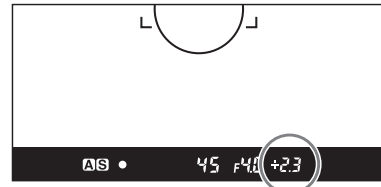
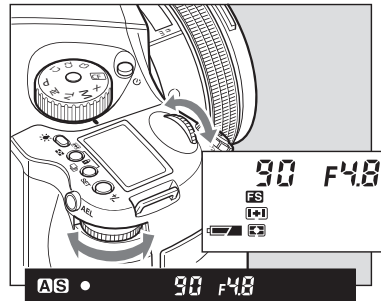
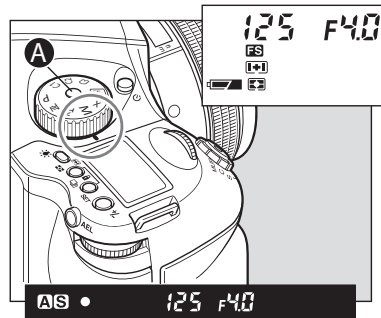

### Manual Mode (M)

This mode is used to set both the aperture and shutter speed for total exposure control. Varying shutter speeds can be selected, including "bulb", "tIME" and manually from 60 mins to 1/4000 sec. Aperture values can be set from maximum to minimum aperture.

1. Turn the exposure mode setting dial to "M" (Manual) position.
2. Turn the rear dial to set the desired aperture.
3. Turn the front dial to set the desired shutter speed.
4. When the shutter release button is halfpressed, the difference between the present settings and the metered value is displayed in the viewfinder's LCD panel. The value is displayed in 1/3 stop increments within a range of  $\pm 6$  EV.

When the difference between the set value and the metered value is greater than  $\pm 6$ EV and the set value is lower than the metered value, the indicator in the viewfinder LCD shows "- u -." Contrarily when the set value is higher than the metered value, the indicator shows "- o -."



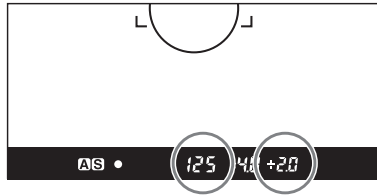

**Notice:**  
The aperture level can be selected for the parameter to shift. C-13 One push M-mode [OnEP]

**Notice:**  
Photography using the leaf shutter or focal plane shutter can be selected in customs settings  
C-17 Choose shutter function Program mode [Sh\_P]  
C-18 Choose shutter function (when in M mode) [Sh]

**Notice:**  
The selected aperture value can be locked.  
When 1/800 sec. shutter speeds can not be achieved even though the leaf shutter lens is attached, try another exposure mode.

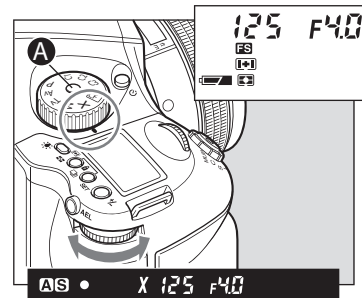
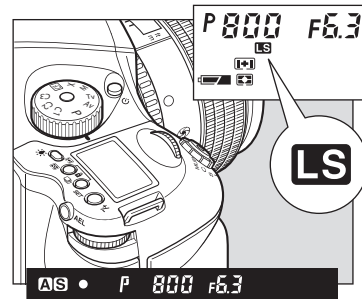
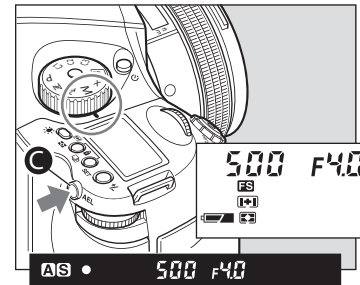
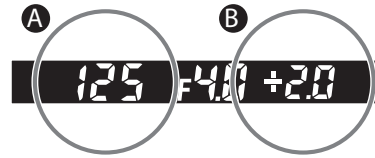

### One-push shift function

When difference between the set value and metered value is displayed on the viewfinder LCD in the Manual “M” mode, press the AEL button for approx. 1 second and the camera will automatically adjust the shutter speed to achieve the correct exposure based on the set aperture value.

While the difference[B] between the set value[A] and the metered value is displayed on the viewfinder LCD, press the AEL button[C] for approximately one second. The camera changes the shutter speed to an appropriate level.

### Auto Mode mechanism

When using the leaf shutter lens, the leaf shutter’s working range is from 1/800sec. to 1 sec. for other speeds (1/4000-1/800 sec., 1-60sec., bulb) use the focal plane shutter.

### Synchro Mode (X)

Select this mode when you use a flash. press button[A] and choose the “X”. The shutter speed will be fixed at 1/125 second for synchronization

### 3.8 Exposure on Leaf shutter vs. Focal plane

Exposure Mode	Lens Mode	Shutter speed			X-Sync		
		1/4000-1/800	1/800-1S	1S - 30S+	1/4000 - 1/800	1/800 - 1S	1s - 30S+
Program	Leaf Shutter	—	LS	—	—	LS	—
	Focal Shutter	FS	FS	FS	—	1/90 - 1S	—
Tv	Leaf Shutter	—	LS	—	—	LS	—
	Focal Shutter	FS	FS	FS	—	1/90 - 1S	FS
Av	Leaf Shutter	—	LS	—	—	LS	—
	Focal Shutter	FS	FS	FS	—	1/90 - 1S	—
Manual	Leaf Shutter	—	LS	—	—	LS	—
	Focal Shutter	FS	FS	FS	—	1/90 - 1S	FS
	Auto	FS	LS	FS	—	LS	FS
X(*)	Leaf Shutter	—	1/125,90,60	—	—	1/125,90,60	FS
	Focal Shutter	—	1/125,90,60	—	—	1/125,90,60	—

### 3.8 Flash photography

Phase One 645DF is equipped with a horizontal focal-plane metal shutter and it is also possible to use leaf shutter lenses.

The focal-plane shutter provides higher shutter speeds than that of leaf (central) shutter lenses. Focal-plane shutters allow you to shoot fast enough to freeze a moving target. Leaf shutter lenses will allow higher shutter synchronization to flash. As a result you will be more able to freeze movement when using strobes.

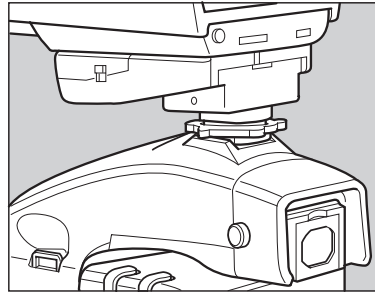

The focal-plane shutter method allows for shutter speeds of up to 1/4000 sec. When shooting at higher speeds e.g. 1/500 sec. the two shutter blades are moving parallel creating a small slit allowing a small fraction of light to reach the sensor area of the digital back. When using this type of shutter it is not possible to achieve flash synchronization greater than 1/125 sec.

A leaf shutter will make it possible to achieve higher shutter and flash sync speeds. However the highest shutter speed the leaf shutter is capable of 1/1600 sec. on P 40+ and P 65+, the max achievable shutter speed on other backs is 1/800 second.

1. To use a grip type flashgun or a strobe with electric contacts other than X contact, use a sync. cord to connect to the camera's sync terminal. (See note below about flashes designed exclusively for other camera makes.)
2. Turn the exposure mode setting dial and set it to "X" (1/125 sec.) or "M" (manual). When "M" (manual) is selected, turn the front dial and set the shutter speed to 1/125 sec. or slower.
3. Turn the rear dial to set the aperture, and then take the picture.

In addition to its standard flash sync system, the Phase One 645DF features TTL (through the lens), off the film (OTF) and electronic flash exposure metering.



#### NOTICE:

This camera's synchro contact is an X contact.

Using flashes designed exclusively for other camera manufacturers in the hot shoe may damage the camera's internal mechanisms. In this situation, use an off-camera flash bracket and connect a sync. cord to the camera's synchro terminal.

When using flashes with a flash duration of 1/500 sec. or longer, set the shutter speed to 1/30 sec. or less.

## Metz 3952 functions

<b>Charging completed indicator in viewfinder</b>	When charging of the flash is completed, a charging completed flash icon  will illuminate in the viewfinders display panel
<b>Automatic setting of flash synchronizing speed</b>	When exposure mode is set at "AV" or "P", the shutter speed will be automatically set to 1/60 to 1/125 sec. when charging of the flash is completed. When exposure mode is at "TV" or "M" and the shutter speed is faster than 1/125 sec., the shutter speed will be automatically set to 1/125 sec.
<b>Flash confirmation</b>	The flash charge mark  flashes after the shutter is released to indicate that the flash was emitted properly
<b>Auto zoom control</b>	The power zoom reflector is linked to the lens focal length (excluding the Metz 32Z-2)
<b>Auto AF assist beam</b>	When the focus mode is set to "S", the autofocus assist beam is emitted automatically in low light. (excluding the Metz 32Z-2)
<b>Display of flash range (distance)</b>	Displayed on the flash's liquid crystal display panel. (Metz 32MZ-3 and Metz 32Z-2)
<b>Data transfer</b>	The film sensitivity data, exposure compensation data and aperture data are sent from the camera to the flash.

Adapter	Type of flash	SCA3952 Module	Converter
<b>Metz Flash Unit</b>			
<b>Metz 44 MZ-2</b>	shoe-mount	x	
<b>Metz 54 MZ-3</b>	shoe-mount	x	
<b>Metz 45 CL-3 &amp; 4 Digital</b>	Handle-mount	x	<b>SCA 3045</b>
<b>Metz 60 CT-4</b>	Handle-mount	x	<b>SCA 3000</b>
<b>Metz 70 MZ-5 &amp; 4</b>	Handle-mount	x	

For more info on Metz, contact the local Metzdealer or [www.metz.de](http://www.metz.de)

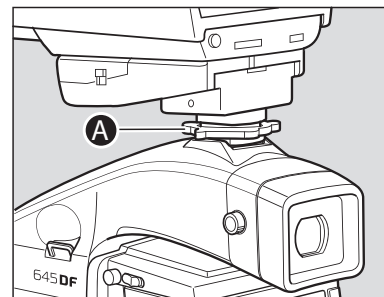

Phase One 645DF features TTL (Through The Lens), OTF (Off The Film) and electronic flash exposure metering. A flash sensor located inside the camera body reads the flash light reflected off the surface of the CCD at the moment of exposure. The sensor is connected via the Phase One 645DF's dedicated hot-shoe to a shoe or handle-mount style Metz flash unit via the Metz SCA 3952 TTL Adapter. Maximum flash speed is 1/125 sec. when the focal plane shutter is used, making daytime synchronization possible.

The ISO of the flash is automatically set through the TTL connection from the camera's film magazine; any adjustment to this is instantly recognized after the setting is locked and the shutter release is half-pressed.

To utilize the TTL flash feature with all TTL-operable Metz flash units, a Metz SCA 3952 module is required. Please see the chart below for capability and/or additional adapters that may be necessary.

The resulting flash exposure automation determines correct flash exposure and automatically adjusts the output of the flash. It also automatically corrects for exposure compensation normally required when using filters, close-up bellows or extension tubes.

1. Mount the SCA3952 adapter onto the Metz flash, insert fully into the camera's hot shoe, and then tighten with the locking knob **[A]**.
2. Set the exposure mode, and then check the shutter speed and aperture.

Exposure mode		Shutter speed	Aperture
P	Program AE	Automatically set by camera to 1/60 sec.	Automatically set by camera
Av	Aperture priority AE	when the metered shutter speed is 1/60 or slower, and 1/125 when it is 1/125 sec. or faster.	Any aperture
Tv	Shutter priority AE	Automatically set by camera to 1/125 when the set shutter speed is 1/125 sec. or faster.	Automatically set by camera
M	Manual mode		Any aperture
X	Synchro mode	1/125 sec. or via CF	Any aperture

### Example:

- (1) When the size of the subject you want to light with the flash is relatively small within the picture
- (2) When the background behind the subject is extremely bright or when there is a strongly reflective object in the background
- (3) When the background behind the subject is extremely dark (outdoors at night, etc.)
- (4) For flash photography with a narrow film latitude



### Curtain Syncro

When a moving subject has been shot under this function, the flash of light appears after the moving subject.

Rear curtain sync mode

Front curtain sync mode

This function is set by Custom function setting.

[Read more on C-15 Flash sync. timing \[FLSY\] on page 91](#)

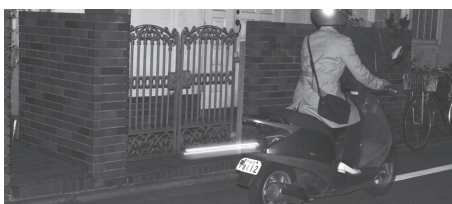

### NOTICE:

With TTL flash photography, the reflection of the flash is metered and the intensity of the flash is adjusted automatically, so TTL flash photography may not be able to suit to all conditions. In the cases described below, we recommend that you use a flashmeter to check the intensity of the flash or to use a manual flash setting.

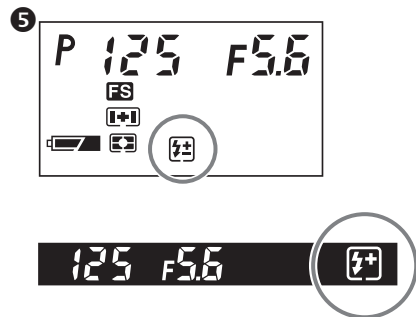
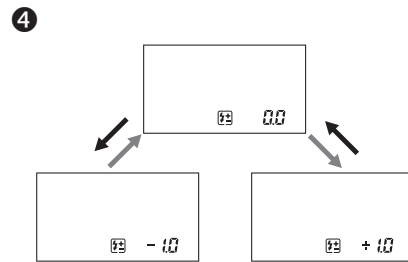
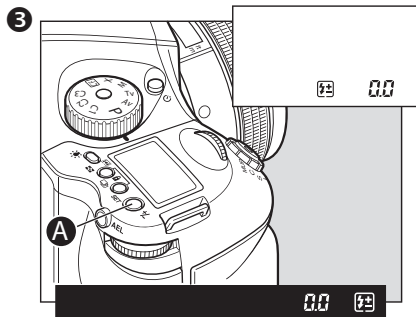
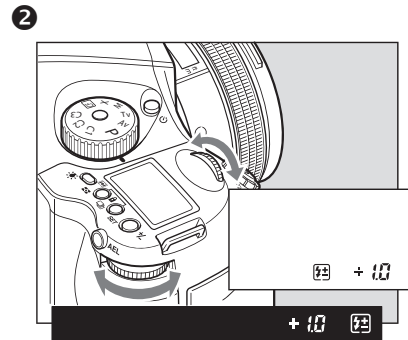
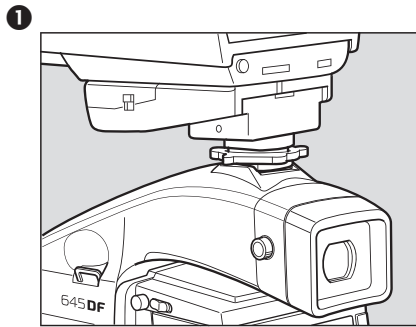

### 3.9 Flash compensation settings

By combined use of a Metz flash and the SCA3952 adapter, the camera adjusts for flash. It can be adjusted within  $\pm 3\text{EV}$  in increments of  $1/3$  steps.

1. Turn on the power

Install the SCA3952 adapter on the Metz flash, and put it on the camera then lock the flash in place using the locking knob on the flash shoe. Turn the shutter release mode selector lever to the “S” or “C” position, and turn ON the flash power switch.

2. When the flash charge confirmation lamp lights, press the set button [A] in. The is displayed on the main LCD panel.

3. Turn the front or rear dial to select the flash compensation value. External LCD Panel (normal display)

4. When the shutter button is half-pressed, the display appears on the external LCD, and appears on the LCD inside the viewfinder with a + compensation, or appears with a - compensation.

#### Viewfinder LCD readouts

- If the flash-charge mark is not displayed, the flash compensation button [A] can not be used.

- Keep pressing the set button to activate the flash compensation mode. You can check the exposure compensation value.

- If you turn the shutter release mode selector lever to the “L” (power OFF) position, the compensation value will be canceled.

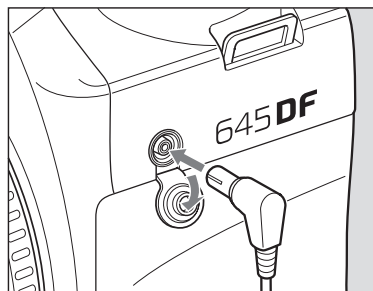

### Flash Photography with electronic flash models other than Metz

1. To use a grip type flashgun or a strobe with other electric contacts than X contact, connect the sync. cord to the camera's sync. terminal. (See note below about flashes designed exclusively for other maker's cameras.)

2. While pressing the unlock button, turn the exposure mode setting dial and set it to "X" (1/125 sec.) or "M" (manual).

When "M" (manual) is selected, turn the front dial and set the shutter speed 1/60 to 1/125 sec. or slower.

3. Turn the rear dial to set the aperture, then take the picture. (for "M", use the rear dial. For "X", use the front dial).

This camera's synchro contact is an X contact.

#### Notice:

Using flashes designed exclusively for other maker's cameras may damage the camera's internal mechanisms if connected to the camera's hot-shoe. In this situation, use an off-camera flash bracket and connect a sync. cord to the camera's synchro terminal.

- When using flashes with a flash duration of 1/500 sec. or longer, set the shutter speed to 1/30 sec. or less.





### NOTICE:

After taking pictures using the exposure compensation feature, be sure to return the exposure compensation dial to the “0” position.

The exposure compensation dial is locked at the “0” and positions.

The exposure compensation feature is available during AE locked operation.

The width of the exposure compensation step can be changed.

Read more on C-01 Steps of aperture, shutter speed, exposure compensation. [StEP] on page 90

The maximum amount of the compensation can be set either at  $\pm 3$  or  $\pm 5$ . Read more on C-05 Auto bracketing steps [Stno] on page 90

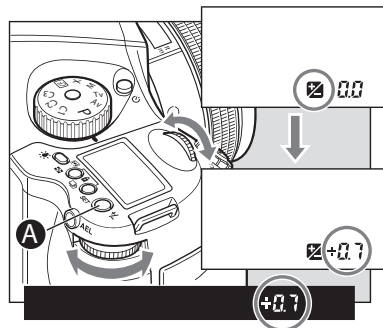

## 4.0 Advanced functions

### 4.1 Exposure Compensation

In situations providing extreme high contrast, the resulting photograph may be under- or overexposed. When this occurs, use the exposure compensation function. Exposure compensation can also be used when you want to intentionally create overexposed or underexposed pictures. Please keep in mind; you can do quite a lot of work using the High Dynamic Range Tool and Exposure Tool in Capture One.

#### With the exposure compensation dial

1. When the exposure compensation button **[A]** is pressed shortly, **[A]** appears on the external LCD. When the front or rear dial is turned counter-clockwise, the exposure is increased; conversely, when it is turned clockwise, it is decreased. The exposure compensation value can be checked on the external LCD or LCD inside the viewfinder.
2. After taking the pictures, press the exposure compensation button **[A]** again to return the exposure compensation value to 0. The exposure compensation value mark on the external LCD is cleared, and the exposure compensation function is released.

Exposure mode	Exposure compensation display	
<b>P</b>	Program AE	The set value is displayed
<b>Av</b>	Aperture Value Priority	
<b>Tv</b>	Time Value Priority	
<b>M</b>	Manual Mode	The difference between the metered value and the set Exposure value is displayed
<b>X</b>	Sync Mode	Not displayed

### NOTICE:

[ ] in the viewfinder LCD blinks to indicate the exposure is locked, when you continue to take the next picture in the AE lock mode.

If you turn the shutter release mode selector lever to the “L” (power OFF) position, or after elapse of one hour, the AE lock mode will automatically be cancelled.

In the Manual “M” exposure mode, you cannot use the AE lock function.

When the difference between the metered value and the set value is displayed, press the AEL button [A] for approximately one second, and one-push shift function will be activated and the camera will automatically adjust the shutter speed.

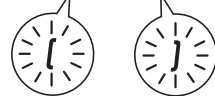
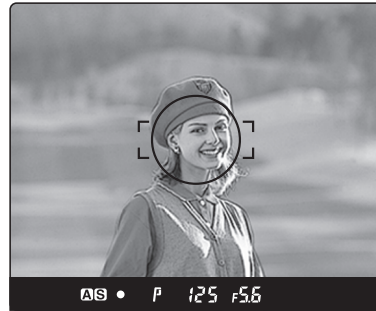
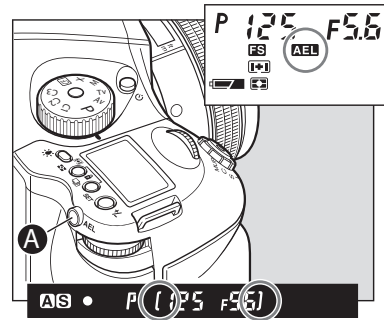

## 4.2 AE Lock

Shooting with the AE lock function is useful in cases where the subject to be brought into focus differs from the subject whose exposure is to be measured or when measuring the exposure of a particular part to be brought into focus using spot exposure metering mode while that part is on the shooting screen.

The AEL button will lock the Auto-exposure value as the photo is being recomposed.

1. Turn the shutter release mode selector lever to “S” or “C.”
2. Turn the exposure mode setting dial and select any of “P”, “Av”, or “T”.
3. Focus on the subject for metering exposure, and press the AEL button on the rear of the grip. [ ] Will appear on the viewfinder LCD, indicating that the exposure value is locked.
4. Slide the camera to recompose the shot, and take the picture.

When you press and hold AEL button the over/under exposure value will be shown to the far right in the viewfinder LCD.

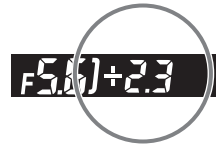

## Metered-value difference indicator

Keep pressing the AEL button **[A]** and the difference between the metered exposure value and the exposure of the new composition will be displayed on the viewfinder LCD. This function can be used to see if an object of very different brightness levels can be properly photographed.

If the difference between the set value and the metered value exceeds 6EV, the viewfinder LCD blinks “- u -” for underexposure and “- o -” for overexposure.

By turning the front or rear dial in the AE lock mode, you can change the aperture and shutter speed value without changing the exposure value that is set when entered into AE lock mode.

In the “P” mode (Program AE) mode, turning either the front or rear dial shifts the program to “PH” and “PL.” When in “Av” (Aperture-priority AE) or “Tv” Shutterpriority AE), turning one of the dials changes both the aperture and shutter speed values.

### NOTICE:

The way to cancel the AE lock can be changed. [C-11 AEL function lock/unlock mode \[AEL\]](#)

Half-pressing of the shutter release button can activate the AE lock mode. [C-10 Half-press shutter release function mode \[HALF\]](#)

The assignment of the AEL button and AFL button can be swapped by using [C-09 AEL & AFL function button exchange \[AEFL\]](#)

Exposure compensation and auto-bracketing function can be used when the camera is in the AE lock mode in normal operation or with the mirror locked up.

**NOTICE:**

When you want to cancel the auto-bracketing mode, turn the rear dial to change “On” to “OF”

**NOTICE:**

After multiple turns, the mark [RP] will appear in the main LCD.

Repeat turning will lead to a countdown being displayed on the main LCD and after taking a photo the camera will return to auto bracketing mode.

By pressing any other button or leaving the camera for 5 seconds, setting for the auto bracketing will be stored.

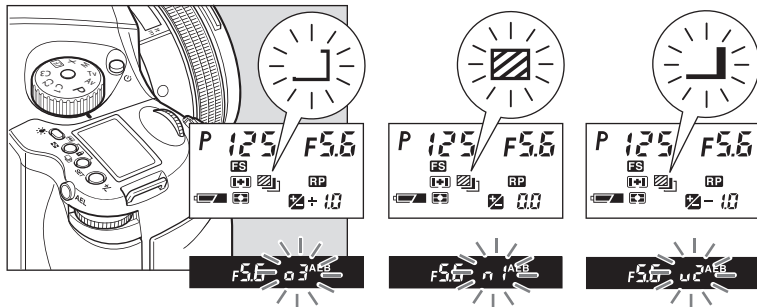
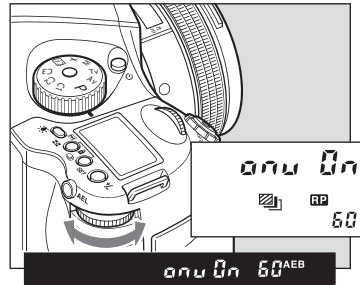
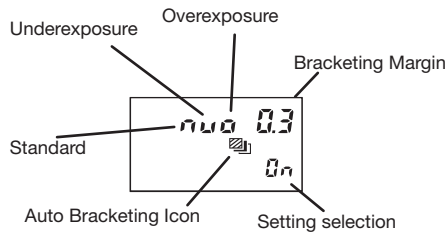
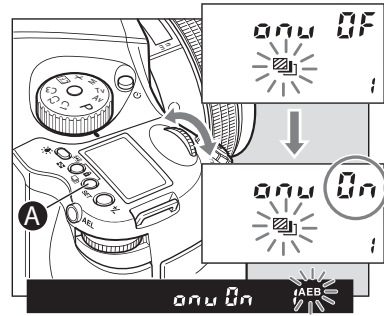

Over exposure

Normal exposure

Underexposure

**4.3 Auto Bracketing**

When it is difficult to determine your exposure compensation value you can use the auto exposure bracketing feature. This allows you to automatically capture different exposure variations in succession. The number of frames to be taken, the bracketed shooting sequence, bracketing margin and other settings can be selected as desired for shooting in auto bracketing mode.

1. Turn the shutter release mode selector lever to the “S” or “C” position. When set at the “S” position, you can shoot one frame with each press of the shutter release button. In the “C” mode, the camera takes a series of three (or two) frames successively with one press of the shutter release button.

2. To turn on auto bracketing keep pressed the auto-bracketing button[A] for approximately one second, the auto bracketing mark will blink on the top LCD panel. Turn the front dial before this indicator goes out, and change “OF” on the display to “On”.

3. The rear dial can also be used for setting. From 1 to 10 turns the value increases in single units, while 10 to 60 turns means increases by units of 10. This will allow you to do more bracketing sessions without re-setting the bracketing function.

4. Press the shutter release button. When the shutter button is pressed in auto bracketing mode the shooting sequence and auto bracketing mark blink on the LCD inside the viewfinder. Furthermore, the auto bracketing mark blinks, the bracket step width is displayed, and the shooting sequence can be checked on the external LCD.

5. After taking pictures, press auto bracketing set button[A], turn the rear dial, set auto bracketing mode to “OF,” and release. Then press the auto bracketing set button [A] or half-press the shutter button to return to the normal display mode.

### AE settings under auto-bracketing mode

	Exposure Mode	Setting
<b>P</b>	Program AE	Shutter speed varies
<b>Av</b>	Aperture Priority AE	Shutter speed varies
<b>Tv</b>	Shutter Priority AE	Aperture varies
<b>M</b>	Manual Mode	Shutter speed varies
<b>X</b>	X-sync mode	No setting

### Single-Frame Mode (S)

Press the shutter release button for each shot.

The camera meters adequate exposure value for each shot and performs auto-bracketing. The camera stays in the auto-bracketing mode until you cancel the auto-bracketing mode manually.

### Continuous Mode (C)

By pressing the shutter release button once, the camera takes 3 (or 2) shots in series. With each press of the shutter release button, the camera repeats auto-bracketing. The standard (normal) exposure value will be fixed when you take the first frame.

### Canceling Auto Bracketing

When you want to cancel the auto-bracketing mode, turn the rear dial to change “On” to “OF”.

#### NOTICE:

When exposure compensation is initiated by pressing the exposure compensation button, shooting in auto bracketing mode is possible using the exposure value to which the exposure compensation value has been added.

### NOTICE:

Auto bracketing exposures can be made when the auto bracketing mode is set before taking photos with mirror up.

After 10 seconds, mirror up photography will be cancelled

The mirror will return to the original position if the lens is removed from the camera body

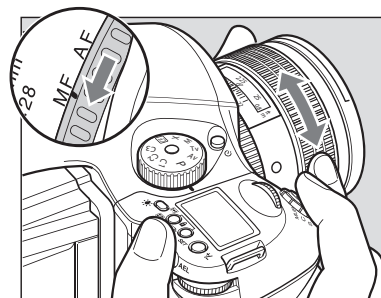
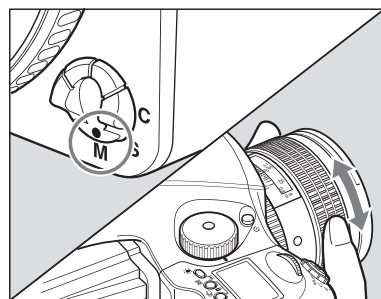
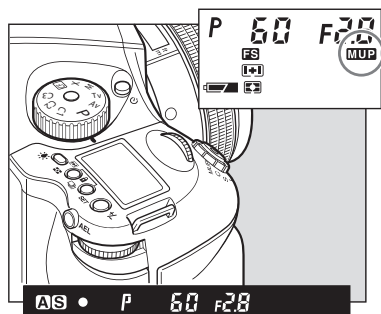
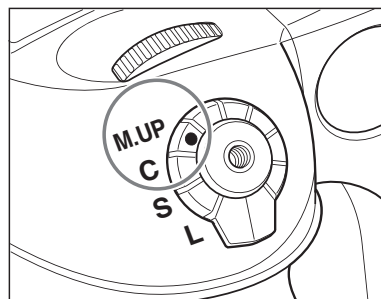

### WARNING:

DO NOT point the lens at the sun during the mirror up mode. The sun's intense light can scorch and damage the shutter curtain.

## 4.4 Taking photos with the mirror up

This function prevents mirror-caused vibrations which may blur the image in close-up photography, when shutter speed is slow, when a telephoto lens is used, or when photographing a poster or e.g. still-life.

When using the mirror-up, Electromagnetic Cable Release RE401 (optional) is recommended.

### In The Auto Focus mode

1. Set the drive dial to "M.UP"
2. Select "S" (single focus mode) by turning the focus mode selector lever.
3. Turn the exposure mode-setting dial to choose any of "P", "Av" or "Tv" exposure mode.
4. Focus the subject, and determine composition and exposure
5. The mirror moves up when the shutter release button is fully pressed.
6. Pres the shutter release button again to take pictures.

### In the manual mode

Follow steps 1 through 3 of the above auto focusing steps and continue with the steps below.

- 1-3 (reference steps 1-3 in the Mirror Up Autofocus method)
4. Set the focus mode selector lever at "M" (manual focus mode) position. Turn the lens-focusing ring to focus.
5. Determine the exposure, focusing and frame structure by pressing the shutter release button halfway while looking into the view finder.
6. Lock the mirror up by pressing the Shutter release button.
7. Pres the shutter release button again to take pictures.

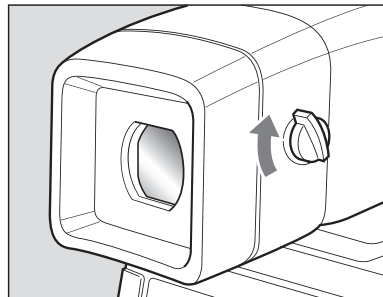
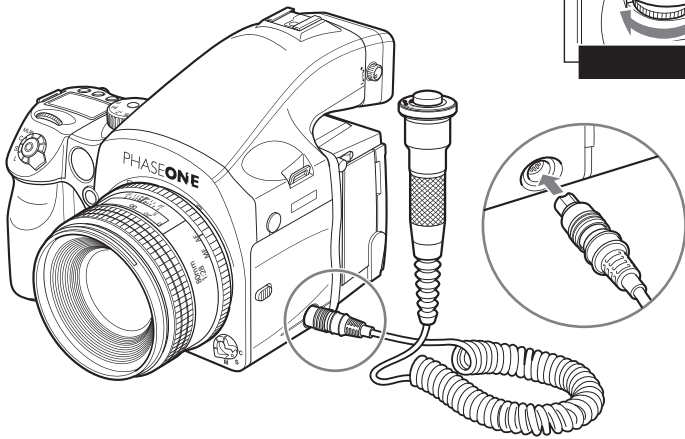
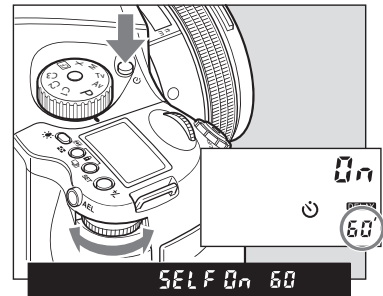
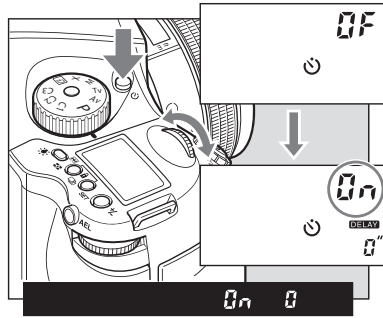

### Mirror up delay

To change from the self timer setting to the mirror up setting, press the shutter button so the mirror goes into the upright position and once the set time has expired the shutter will release, and the mirror will return to the lower position. Separately purchased electronic cable release RE401 can be used to eliminate camera shake.

When using auto focus the operational method is the same as 1 to 3 when using M.UP and autofocus.

1-3 (reference steps 1-3 in the Mirror Up Autofocus method”

4. Press the self timer button and turn the front dial to “ON”

5. Turn the rear dial to select the time needed. 0.5/1 seconds to 10 seconds allows for increases by the second, 10 to 90 seconds increases by 10 seconds per turn. For 2 to 10 minutes the value by the minute and 10 to 60 minutes increases by 10 minutes per turn.

6. Line up the photograph through the viewfinder and half press the shutter button to ensure the focus and framing is correct.

7. Press the shutter button completely and the mirror will go to the upper position, then after the set time the shutter will release and the mirror will return to the lower position.

### Electronic shutter release contact

For mirror-up, long exposure, or slow shutter shooting, use the magnetic cable release RE401 or the remote control RS402. The assisting release contact is to insert the cable.

### Eyepiece shutter

Close the eyepiece shutter when there is a strong light source behind the camera.



### NOTICE:

As the camera is electronically controlled even during exposures, it is recommended to replace batteries before bulb exposure.

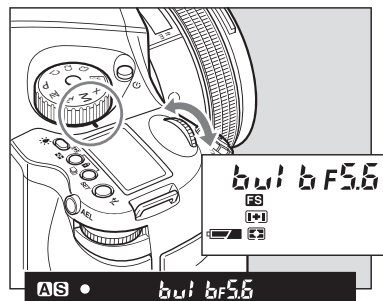

### NOTICE:

Using "tIME" (Time) setting, the shutter will open and close according to the number of times you press it.

"tIME" (Time) photography is electronically controlled so it is possible that the batteries will drain quickly. In the case, please replace the batteries with new ones.

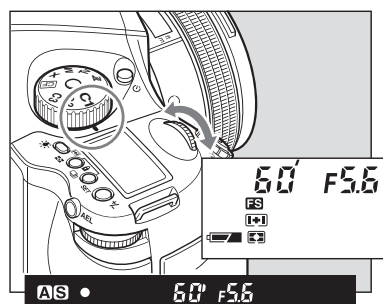

### NOTICE:

When releasing the shutter, or pressing the backlight button [A] while the backlight is on, the backlight will go OFF.

Choose the time of display light. C-03  
Time to sleep [HOLD]

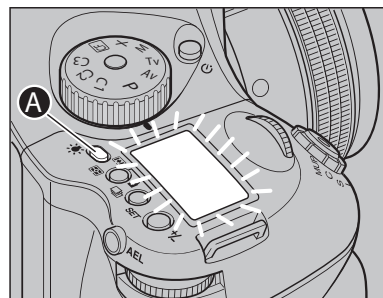

## 4.5 Bulb Mode & Long exposure

To make an exposure longer than 30 seconds, adjust the shutter speed to "B" (bulb). In order to prevent camera shake, use the RE401 or RS402 electromagnetic shutter release and tripod.

1. While pressing the unlock button, turn the exposure mode dial and set it to "M" (manual mode).

2. Turn the front dial to select "bulb", then turn the rear dial to set the aperture.

3. Determine the composition, focus, and then take the picture. The shutter remains open as long as the shutter release button is pressed.

### Setting long Exposures

When photographing under normal conditions, the shutter speed can be adjusted for longer exposures.

Turn the front dial for shooting time settings. New time settings include 1, bulb, tIME(Time), 2, 4, 8, 15, 30, 60.

## 4.6 Camera display light

To see the top display at night or in dark places, press the backlight button [A] / .

The backlight will go on approximately 20 seconds and go off unless there is another operation.

When operating the camera while the backlight is on, the backlight will be lit for approximately another 10 seconds.



### NOTICE:

The setting will be stored after one second.

Dial lock can not be set when the exposure mode is "P" (program AE).

Even while dial lock is set, the front dial or rear dial can still be used to perform the various settings. (Dial lock is temporarily released.)

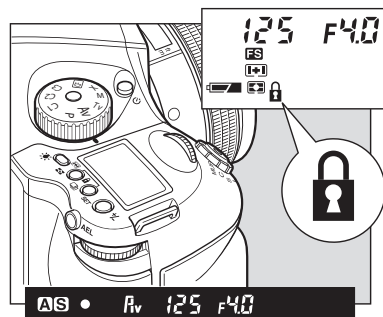
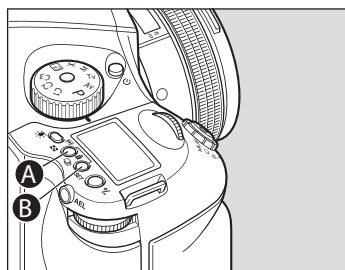
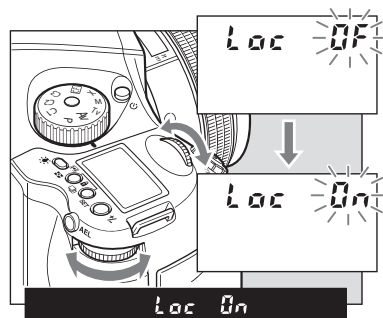

## 4.7 Front/rear dial lock mechanisms

When the Electronic Dial Lock is "On," all currently set values in "Av" (Aperture Priority AE), "Tv" (Shutter Priority AE) and "M" (Manual mode) cannot be adjusted with the front or rear dials. This prevents accidental change of shutter speed or aperture values.

Press down the two lock buttons **[A]** and **[B]** at the same time at the same time for approximately one second, until the "On" indicator blinks.

To release the mode, hold down the same buttons until "OF" blinks.

 is displayed on the main LCD to indicate that operation of the front and rear dials is locked.

When the dial lock is ON, the shutter speed and aperture will not change even if you turn the front or rear dial.

When you activate the electronic dial lock, and if you then operate the electronic dial, the dial lock indicator  on the main panel blinks for three seconds to show that the electronic dial lock is functioning.

**Notice:**

To release the self timer while it is operating, turn off the power (by setting the drive dial to “L”)

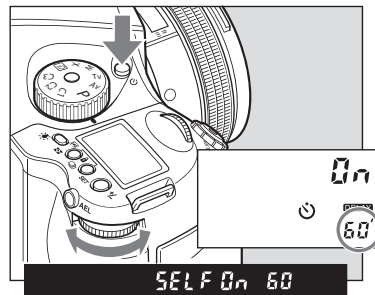
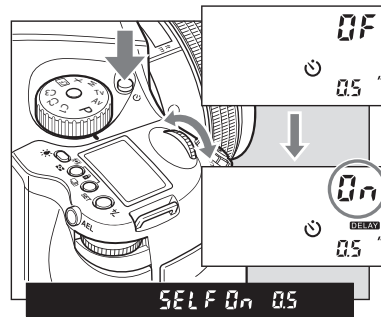

**Notice:**

In the self timer setting, put the drive dial to M.UP (mirror up) mode. Should you wish to operate with mirror up and delay, simply switch the drive dial to M.UP (mirror up) mode in the self timer setting.

### 4.8 Self timer mode

With this function, under the default setting the shutter is released 10 seconds after the shutter release button is pressed. The self timer lamp flashes slowly for the first 7 seconds, and then flashes quickly for the last 3 seconds before the shutter is released. Use this function to avoid shaking the camera when pressing the release button, to take group photos or to photograph yourself...

1. Mount the camera to a tripod.
2. Switch the shutter release mode selector to the  (self timer mode).
3. Turn the front dial, and set the self-timer mode to ON
4. Check the view by looking through the viewfinder. Make sure that the focus is correct, press the shutter release button and the shutter will be released after 10 seconds.

### Changing the self timer duration

1. Press the self timer button to set the self timer mode
2. Turn the rear dial to change the duration of the self timer. 0.5/1 seconds to 10 seconds allows for increases by the second, while 10 to 90 seconds increases by 10 seconds per turn. For 2 to 60 minutes increases by 10 minutes per turn.

### Releasing self timer mode

1. Press the self timer button to set self timer
2. Turn the front dial to “OF”

### Notice:

Repeat turning (according to the number of times) will lead to a countdown appearing in the display.

After setting the interval photography, turn the drive dial to “M.UP” (mirror up mode) and you can operate in mirror up delay mode. While photographing in this setting the “AEL” will be displayed on the main LCD.

When using auto bracketing, the interval function cannot be used at the same time.

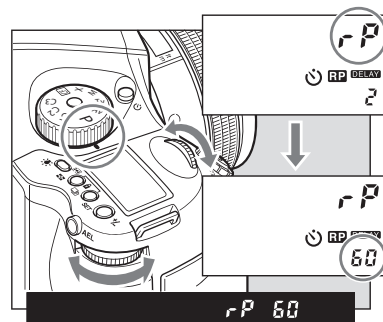
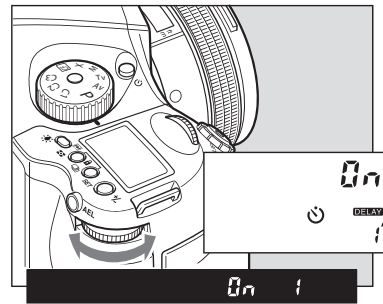
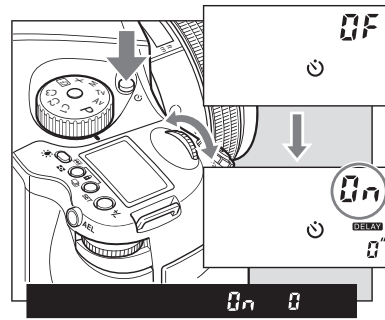

## 4.9 Interval photography

By repeated turning, the interval time can be set automatically. It can be set to suit scenes such as cloud movement or a flower going in bloom.

1. Ensure the camera is firmly secured on a tripod.
2. Press and self timer button twice.
3. Turn the front dial to display interval mode as “On”
4. Turn the rear dial to set the interval time. Settings include 0 seconds (no interval time), 1 to 10 seconds (increased by the second), 10 to 90 seconds (increased in units of 10 seconds), 2 to 10 minutes (increased by the minute) or 10 to 60 minutes (increased in units of 10 minutes per turn).
5. Turn the front dial to the repeat mode to select how many shots you want in your interval session, 1-10, or up to 60 in intervals of 10. if you wish to make a motion film of your session, you need more images, and you can get great advantage by shooting tethered to a computer, and setting the interval to “ON” this way the camera will do a shot until you stop the session, make sure you have enough discspace on your computer.
7. Check the focus and framing in the viewfinder then press the shutter.

### Cancelling interval mode

1. Press the interval mode button for interval mode
2. Turn the front dial to “OF”

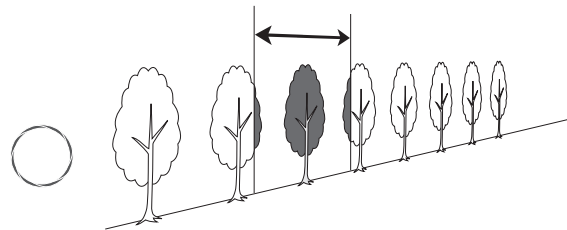
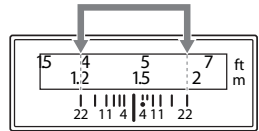

When the aperture is open (the subject depth is small)

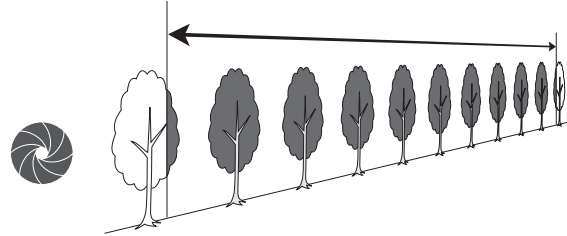

When the aperture is stopped down (the subject depth is large)

### 4.10 Depth of field

Depth of field (D.O.F.) is defined as the zone of sharpness before and behind the plane of focus. It depends on distance to subject, focal length of lens, aperture setting and distance the lens is focused at.

In addition to visual observation via the depth of field preview button, the D.O.F. can be determined by using the depth of field scale on each lens. The f/stop numbers appear on both the right and left side of the white index mark in the center of the scale. Simply read the figures which appear above the f/stop numbers on the distance scale of the lens.

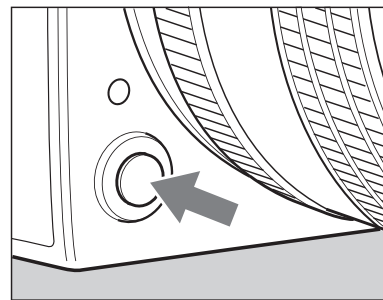

#### Depth of Field Preview Button

When the preview button is pressed in, the depth of field for the aperture set on the camera can be checked by looking through the viewfinder.

After focusing, press the preview button. The diaphragm will be stopped down to the set aperture.

**NOTICE:**  
While operating the preview button,  
you cannot release the shutter

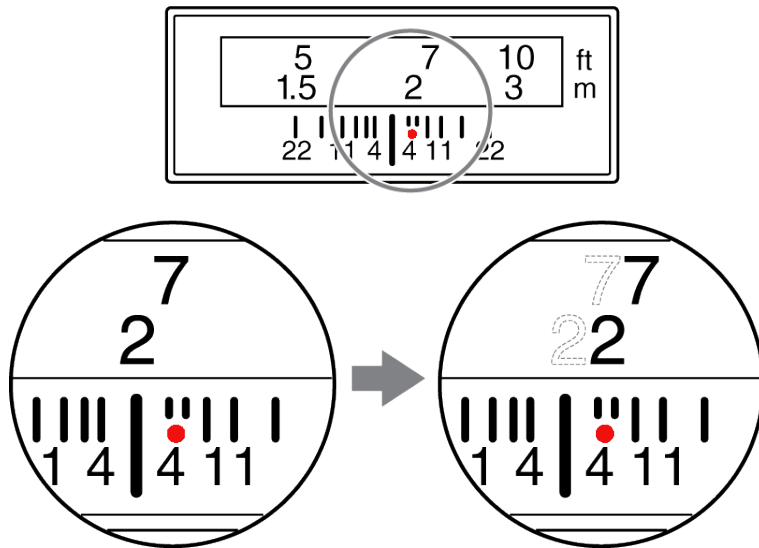

#### 4.11 Infrared photography

Infrared Photography is complicated when using digital backs, as the digital back is adjusted to match the viewable light perfectly.

To make good infrared photography, you need the back adjusted for this or a back dedicated to infrared photography. **DO NOT TRY THIS AT HOME!**

– All corrections in this area must be done by Phase One to ensure the precision. If you remove the protection glass or make other physical adjustments on the back the warranty will immediately be void.

**If you consider Infrared Photography, please contact your local Phase One dealer for technical advice and pricing on this.**

When you have set the distance on the lens, you should always manually correct sharpness, to be in front of the red dot. As the infrared light have a slightly different area of sharpness compared to the viewable light.

Do not use your camera's light meter when photographing infrared, as the light meter is aimed towards reading the visible light.

**NOTICE:**

You cannot take photos in AE modes when using an infrared film as the AE is based on visible light.

## **5.0 Tethered shooting**

Phase One is on the cutting edge of quality and technology, however Phase One still maintains its commitment to being intuitive. It is as easy as plug and play and it is created to match all shooting environments.

### **5.1 Connecting**

Connect the Fire-wire cable to the back of the camera and on the back of your Mac or WinPC – though there can be found computers with Fire-Wire plug-ins on the front, our experience is that the back connection is more stable, and functions better. Capture One will automatically recognize the camera, and settings shared. (Read more on capturing in the software manual).

### **5.2 Driver set-up**

Install Capture One on your computer, follow the instructions provided with the software, and activate the software.

There is no specific program set-up except the set-up or recommended hardware provided in the beginning of this user guide as well as in the user guide for Capture One.

Eventual firmware announcements will be available on our website, and in our newsletters.

### 5.3 Tethered operations

When operating in a studio, connected to a computer via FireWire you are not dependent on battery power or storage media. You can capture directly to the Phase One Capture One Raw workflow software on either Mac or PC, providing power to the P+ back via FireWire without the battery or CF-card inserted.

When shooting tethered to Capture One you can capture your images directly to your currently assigned capture folder on your computer's hard disk. You also have the option to shoot to a CF-card even when tethered.

While tethered you can also choose whether to have your P+ back play back the images as normal, or you can set it to be off.

When unplugging the P+ back from the FireWire, the P+ back will default to untethered mode, capturing to CF-card or microdrive, and using the battery for power.

Also when capturing tethered to a laptop with 4 pin mini 1394/FireWire without power it will require a battery in the P+ back.

If using a laptop with the (non P+) P 20 and P 25 it is necessary to use the Phase One "No Firewire Power Solution" Part.# 70508 to force battery power.

Use the four menu buttons on the back's user interface to setup the preferences for all these operational features.

Consult the Capture One 5 manual for detailed intro to the software.

## 6.0 The Back

The back is a highly developed electronic device. The Phase One backs are created to provide a natural and easy workflow, without creating unnecessary complicated functions or menubrowsing. You can see the menu flow chart here and read more on the menuoptions in this chapter.

### MENU FLOW CHART P & P+ series

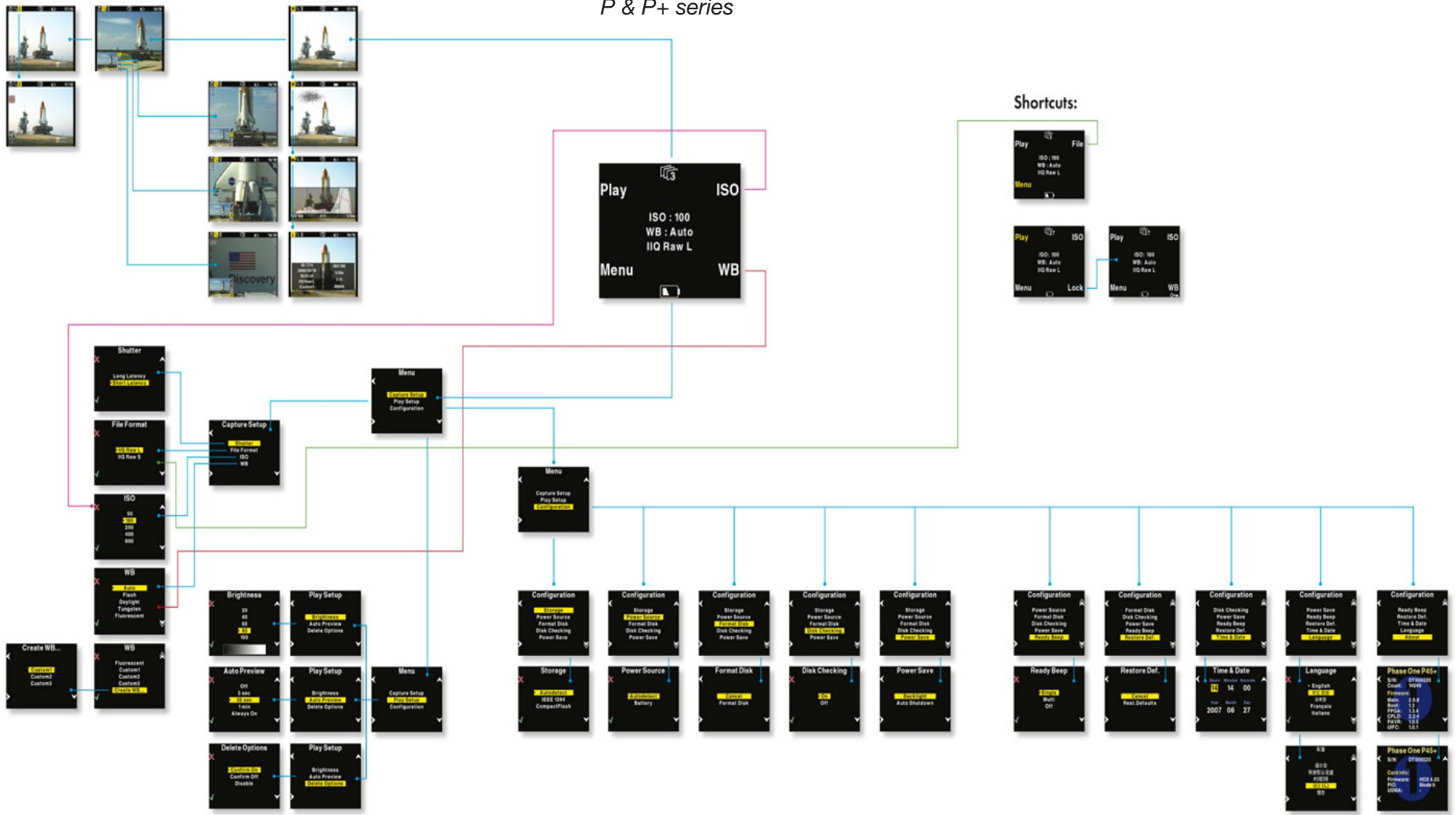



# Flow Chart

## Phase One P 65+

## Phase One P 40+

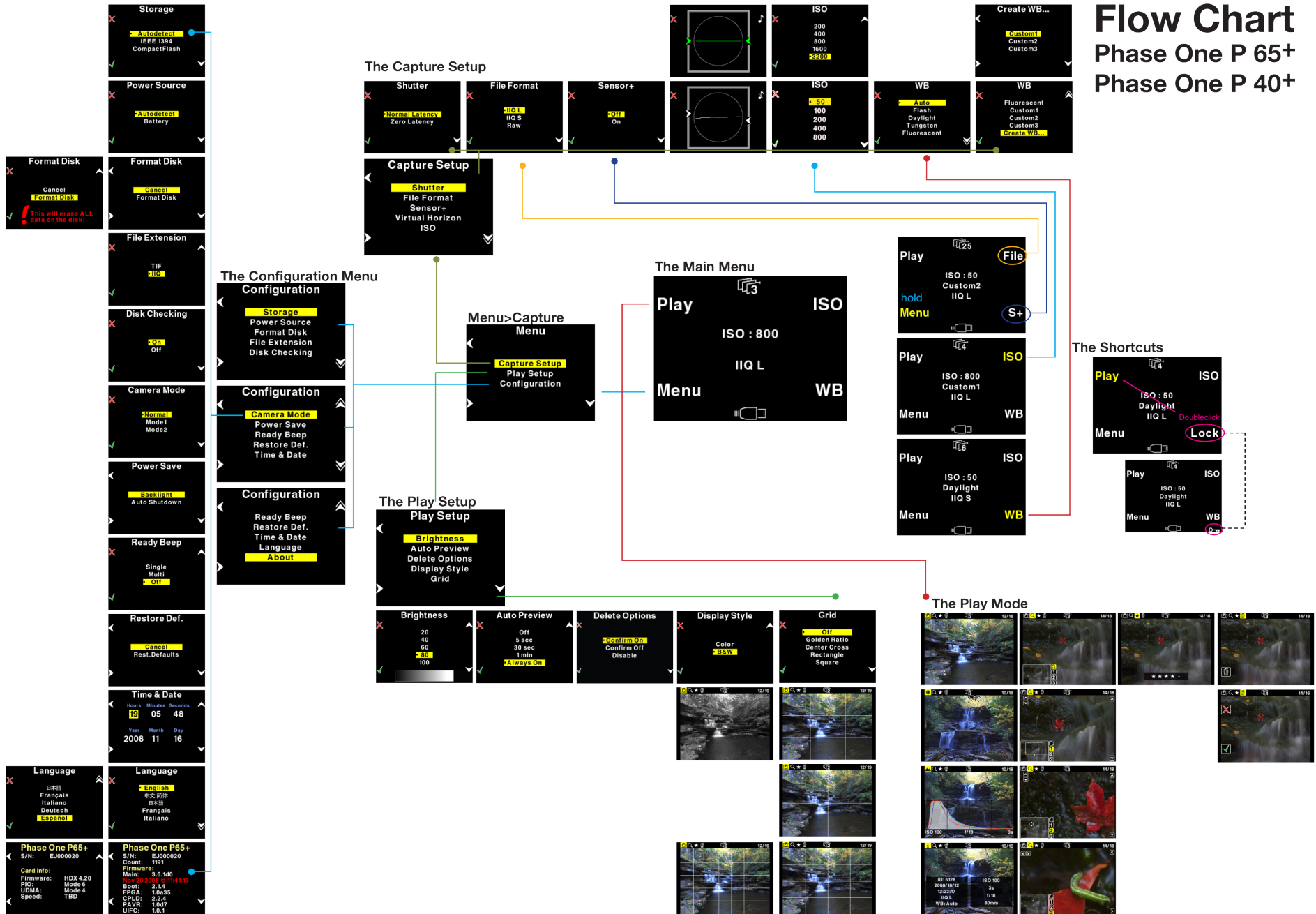

## 6.1 CF card usage

When working with CF-cards, card readers and digital cameras it is very important to follow a few rules to avoid loss of data.

Phase One recommends that you test-drive all new Compact Flash cards (including the one enclosed). By doing an initial test to verify that the capture files are stored properly on the card and can be accessed on a computer you will avoid unpleasant surprises on location or when you return from a job. Compact Flash cards are manufactured by other suppliers, and Phase One cannot guarantee that the cards are not defective.

### Inserting and ejecting cards on the P+ back

The compact flash card or microdrive is inserted in the hidden slot located under the cover on the left hand side of the P+ back.

Insert the card with the brand label facing the display end of the digital back as shown in the image.

When the card is properly inserted the edge of the card will be flush with the edge of the slot allowing the cover to be closed.

To eject the card push the small button just above the card once, and an ejecting pin will come out.

Pushing this pin all the way back in will eject the card.

Although most CF-cards or microdrives come preformatted and ready to use we recommend that you always remember to format your memory card in the P+ back. This will help ensure the best performance from these cards.

Formatting of the memory card is done in either FAT 16 or FAT 32 depending on card size, and if the formatting is done in the P+ back cluster sizes on the disk are set for the best performance.

It is also possible to format the cards on either Mac or Windows, this is explained in the following sections of this chapter.



### CF card usage – 3S the Secure Storage System

When a card is inserted into the P-back, a complete disk check for a valid file structure is performed.

For smaller CF cards the time to load is negligible, however you may notice some lag with larger cards.

Large Microdrives will take a noticeably longer time to load but if the time exceeds 2 seconds a progress bar will appear to illustrate the status.

The progress of a disk check is indicated with series of small dots in the disk icon.

It is not recommended to turn off disk checking, but it is possible by selecting “Disk Checking” available via Menu>Configuration>Storage.

Whenever Disk Checking is turned off the capture counter turns red to indicate that the disk has not been checked.

### Disk Check summary

With the 3S technology we have created a new and safe storage system in the P – back that is much more rugged than anything else seen in the industry.

- Make a complete formatting in the back, no need for formatting on the computer
- Damaged or wrong formatted cards will be detected immediately, and we now also have the ability to reformat the cards to correct them.
- Ejecting a card while in a writing session will not necessarily damage the file structure of the entire CF-card, only the image being written and the images in the buffer can be damaged.
- No other digital back or DSLR camera has this level of storage security!

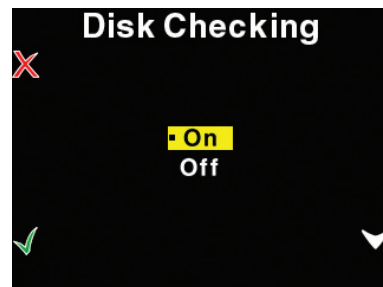

## **6.1 CF card in general use**

Do not eject the card while the P+ back is still writing to the card (red LED is on) as this will cause images and data that are still not written to the card to be lost or damaged.

For rescue tips in situations where the P+ back reports that you have a damaged card, please see the “Sandisk card and Card reader” section.

### **General handling guidelines**

Be careful to not drop your CF cards and especially your Microdrives.

Although compact flash cards are not as vulnerable as microdrives there are still precautions to take. Please keep the card away from moisture and sand and don't bend it. Use the supplied jewel box as a storage container for the card.

### **Using cards in the card reader**

When inserting the card into the card reader on a Mac or PC, the card will be mounted as a removable drive on the computer.

For information on how to import the files to Phase One Capture One, please consult the Capture One online user guide available under “Capture One Help” in the Help Menu.

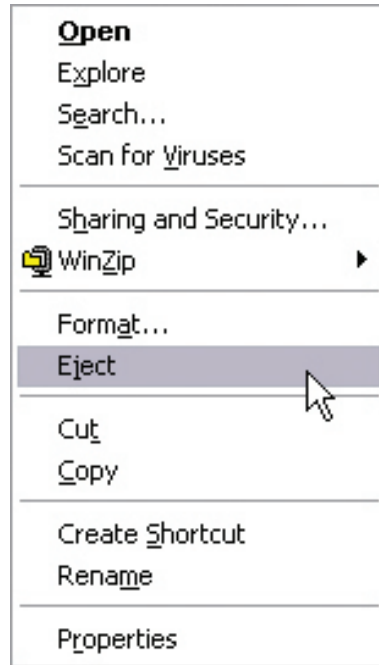

## 6.2 Mounting and dismounting card on computers

On Windows™ computers the proper procedure to eject your CF card is to right click on the icon in “My Computer” and select “Eject”. Not following this procedure can confuse the system and possibly unintentionally damage or erase a CF card.

On a Mac you need to unmount your CF cards you can do this by dragging it into the trash, selecting eject in the “File” menu, or ejecting from the Capture panel inside the Capture One Software.

Just removing it, and reinserting it can confuse the system, possibly resulting in uncontrolled read or write errors. If this happens, restarting the computer usually solves the problems.

### Preparing the CF-cards

Most CF cards are pre-formatted and ready to be used in the P+ back.

The P+ back supports cards formatted in either FAT 16 or FAT 32.

If your card is not recognized in the P+ back it is possibly due to a wrong file system formatting on the card.

Mac HFS, UNIX or NTFS file systems are not supported by the P+ back, and cards with these file systems will not be recognized.

The card will have to be formatted in either FAT 16 or FAT 32 using a computer, Mac OS X or Windows.

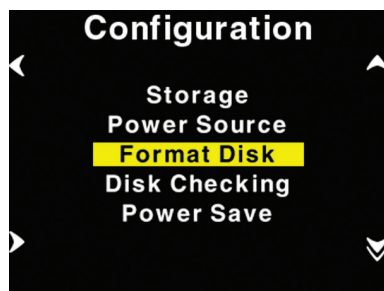

### **Phase One recommends formatting in the digital back.**

Selecting "Format disk" will erase the CF-card in the P+ back. The CF-card will be formatted as FAT-32.

### **Formatting on a Mac OS X computer**

On Mac OS X the formatting cannot be done directly in the finder but is easily done inside the Disk Utility located in the Applications > Utilities folder.

Open the Disk utility and select the Disk (not just the partition, but the entire disk).

Select the Erase panel as shown on next page, and select MS-DOS File System. Give the disk a name and click on Erase to erase and format the entire disk for use with the P+ back.

Choose "Options" in the formatting dialog to specify a complete and thorough formatting of the media.

### **Formatting on a Windows computer**

Insert the CF-card in the card reader, and select the drive when it mounts in "My computer" or in the Explorer.

Right click on the drive and select "Format" from the pop-up menu.

Select FAT32 or FAT16 from the "File System" pop-up.

Give the card a name and click Start to format the card to be used with the P+ back.

To specify a complete and thorough formatting of the media, do not enable the quick erase option.

Disabling iPhoto Autostart (Mac OS X)

iPhoto Autostart can be disabled in the Mac system preference. Select "CD's & DVD's" and change the setting for "Picture CD" to either "Ignore" or point it to the Capture One Application you are using.

### 6.3 Navigating the Back menu

When the P+ back is turned on, the screen will always be in its home display position or “Main screen”. Please note that the P 40+ and P 65+ will have a slightly changed menu, to ensure your information regarding digital backs, it is recommended that you check the individual user guide for the digital back.

Pressing and holding down the upper left button on the back will also bring you to the Main screen, regardless of where you are in the menu system.

The Main screen has a counter at the top showing remaining captures, and a battery indicator at the bottom showing the remaining battery capacity.

When either indicator reaches zero it will start blinking to indicate that either storage or battery needs replacement, before capturing any more images.

The main screen also shows the current ISO setting, white balance setting and IIQ Raw file format selected.

#### Menu buttons

The Phase One P+ back has four menu buttons to control the menu system on the display.

When the P+ back is in its initial state (just after power up) or at the menu systems “home” position (Main screen), the four buttons each have a shortcut assigned. Play, Menu, ISO and WB.

Inside the menu system arrows will indicate the function of the four buttons, the two buttons to the left are used to enter and exit the selected menus. The two buttons to the right are used to go up and down in the menu system.

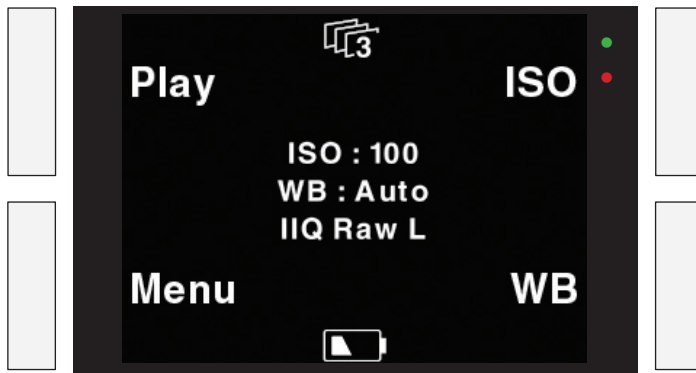



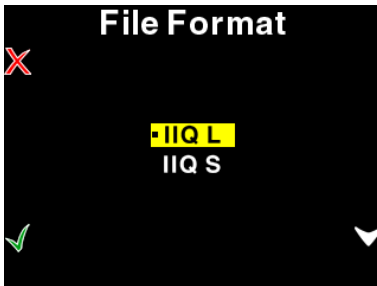
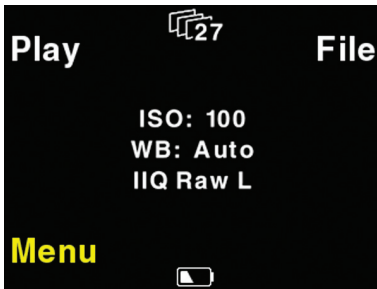
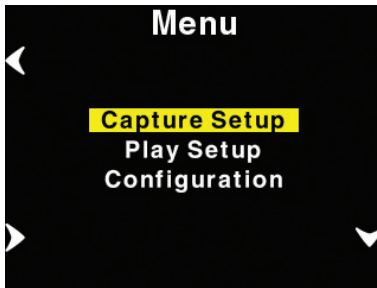

From the home position, pressing the “Play” button will bring up the image browser, where you can go up and down with the right hand buttons, to browse through images.

Pressing the “Menu” button will bring you to the menu system where you can scroll up and down in the menu system with the right hand buttons to select the menu options to set.

When the desired option is highlighted it can be selected by pressing the “Enter” button.

Exiting the menus is done with the “Exit” button.

#### Home shortcut

Holding down the “Exit” button for a few seconds will always bring you to the home position or main screen immediately.

#### File format shortcut

Holding down the “Menu” button while in Home position colors the word “Menu” in yellow, and at the same time reveals a shortcut with the word “File” in the place where ISO was.

Pressing this button at the same time will bring up the File format Menu, where you can select between IIQ Raw L and IIQ Raw S. For more explanation on selecting in the menus please consult the “Menu mode” section later in this manual.



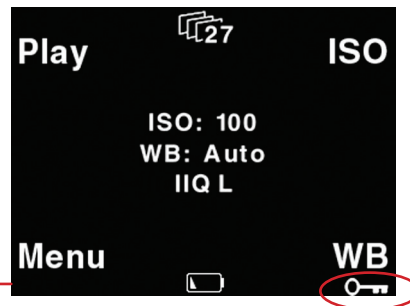
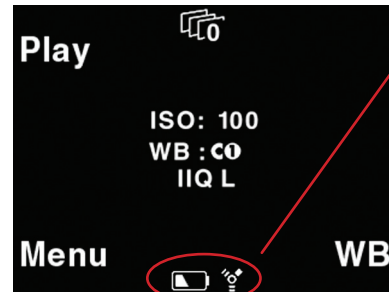
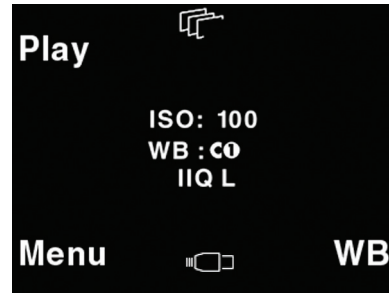
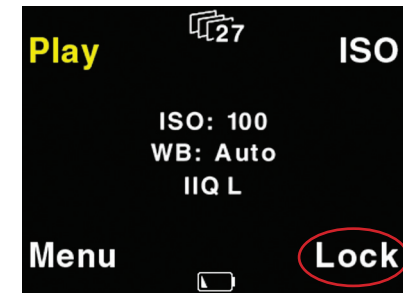
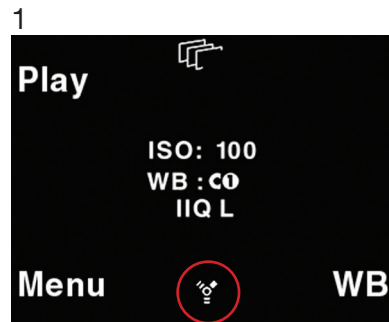
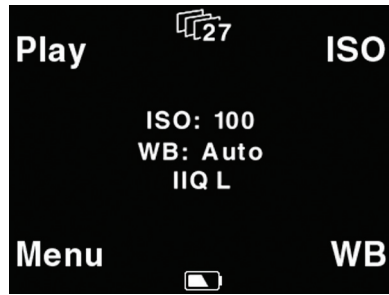

## Battery and Power Indicator

The screen dumps illustrate the battery and power mode indicators.

This is the initial view that meets the user when switching on the P+ back (not connected to a computer).

When a FireWire cable is inserted and the P+ Back draws the power from FireWire this is shown with an icon in the bottom of the main menu. image #1

When Capture One is started on the computer this is indicated with a FireWire icon in place of the cable icon.

When the P+ back is forced to get power from the battery, this is indicated with an additional battery icon.

Force battery power is invoked from the "Configuration > Power Source" menu.

## Button Lock shortcut

Holding down the "Play" button while in Home position colors the word "Play" in yellow, and at the same time reveals a shortcut with the word "Lock" in the place where WB was.

Pressing this button twice when holding down the "Play" will lock operation of the four menu buttons. This is useful to avoid unintended button operation while carrying around the camera. When the buttons are locked, the key icon is displayed just below "WB".

To Unlock the buttons hold down the "Play" button again and tab the "Lock" button twice again.

## 6.4 Playmode

“Play mode” can be used to review, zoom and delete images.

From the “Main screen”, pressing the top left button the P+ back is set to Play mode.

In Play mode the top of the screen will show a menu bar. In the right side of the menu bar the current image number and the number of images captured on the media is displayed. In this example it shows number 5 of 19 images.



Pressing the Up and Down buttons on the P+ back (right hand side) it is possible to browse through the images.

Holding down the “Enter” button while pressing the up and down icon will bring you to the first and last image respectively.

Battery life and number of captures left are also shown in the menu bar.

Pressing the Play button on the P+ back (top left hand button) will step through the options available in the menu bar.

From left to right these are: Review, Zoom and Delete.

Pressing the “Enter” button on the P+ back (bottom left hand button) selects the option.

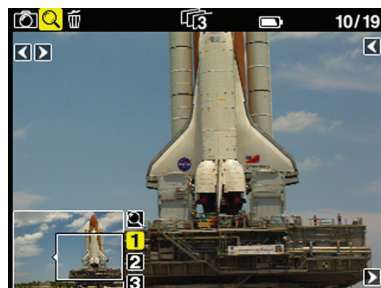
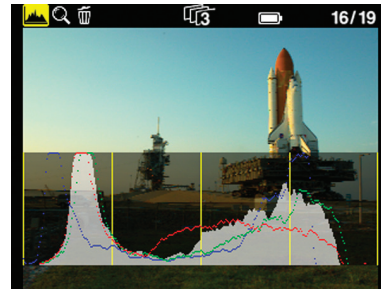

## View modes

Play mode has four view modes, or review modes; Normal image display, Exposure warning overlay, Histogram overlay or File Info overlay.

After entering the Play mode, press the “Enter” button to shift to the view mode you want.

Exposure warning overlay will warn about burned out areas in the image by filling in the blown highlights with a flashing color.

Histogram overlay will show a transparent Histogram over the image.

File Info overlay will show detailed capture information like capture number, capture time, date, ISO, WB, file format and shutter speed, etc.

The setting that Play mode is left in will also be the setting used for review of images while shooting.

This means, that if the Play mode is set to show images with a histogram, and you then exit to the Main screen. All subsequent captures will be shown on the display with a histogram over the image.

## 6.5 Playmode – zoom functions

After entering Play mode, advance to the eyeglass icon by pressing the Play button again and press the “Enter” button to select it.

It is now possible to zoom in the image with the “Enter” button.

The zoom has four amounts, Normal, enlargement 1, enlargement 2 and enlargement 3.

When zoomed into enlargement 1, 2 or 3 the insert view in the lower left corner can be used to navigate around in the image.

A small rectangle will show the current position and the up and down buttons can be used to scroll up and down.

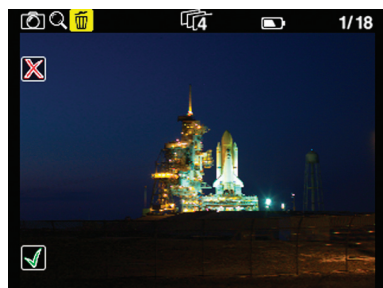
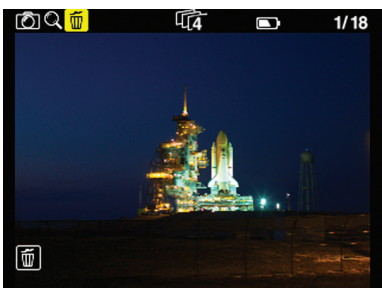
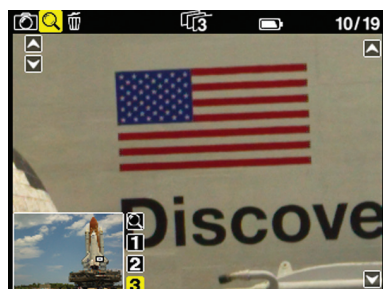
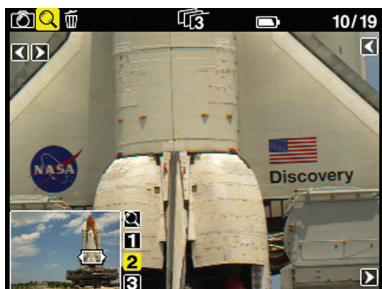

An icon just beside the Play button (top left hand button) will show the direction of scroll as either vertical or horizontal.

Pressing the “Play” button once will change this from horizontal to vertical scroll when using the up and down buttons. (Left side)

To exit the zoom function use the enter key to navigate to the eyeglass icon in the pan view and press the Play button to step to the next icon in the menu bar. Or hold down the “Exit” button for more than 1 second.

### Browsing inside Zoom

While in the Zoom tool (enlargement 1, 2 or 3) holding down the “Enter” key, will hide the two up and down indicators. It is now possible to browse through the images by pressing the Up and Down buttons without leaving the Zoom functions.

This means that the exact same focus point can be evaluated on several pictures in a row by pressing “Enter” - “Up” or “Enter” - “Down”.

### Delete

Navigate to the delete function by pressing the play button.

When in the delete view press the Up and Down buttons to browse through images.

Pressing the Enter button brings up an X or a √ (checkmark). Pressing “Enter” again will select √ and delete the image.

Pressing the exit button will select X and cancel the deletion.

If “Confirm Delete “ is set to “Off” in the “Play Setup”, the X and √ confirmation will be skipped, and the image will be deleted immediately when pressing “Enter” while on the delete menu.

### Exit the Play mode

Exit the Play Setup at any time by holding down the Play button for two seconds.

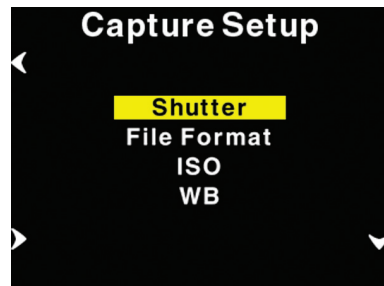
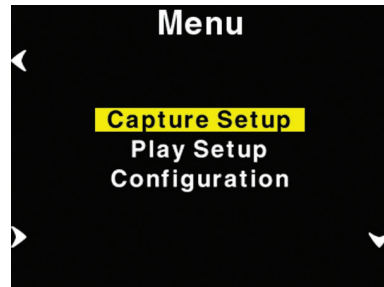
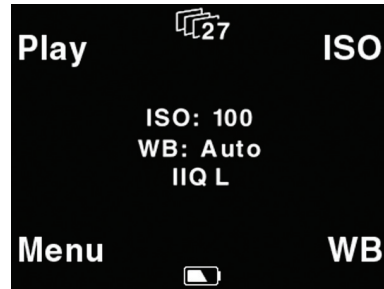

## 6.6 Menu Mode

Pressing the lower left button sets the P+ back in “Menu mode”.

Entering Menu mode by pressing the lower left button allows you to set up all the preferences of the P+ back.

Menus are navigated by following the Enter, Exit, Up and Down arrows and pressing the corresponding buttons on the P+ back.

Whenever you want to exit to the main screen hold down the exit button (upper left button) for more than two seconds, and you will be back at the main screen.

When entering the menu mode you have three options: Capture Setup, Play Setup and Configuration.

### Capture Setup

Capture Setup is where you setup preferences for the capture.

Enter the Capture Setup by pressing the enter button (lower left button)

In the Capture Setup you can select ISO, WB, FileFormat or Shutter.

By scrolling down with the down button you can select the options.

### Shutter

Shutter refers to the shutter of the camera the P+ back resides on.

Due to the sleeping architecture of the P+ back, where the CCD is put to sleep to reduce power consumption, the P+ back needs to wake up before shooting. The timing of this wake up signal is referred to as the latency.

In general, if the camera is used with medium format cameras with digital interface the setting can be either “Short latency” or “Long latency”.



Short latency has a shorter response time, but is power consuming, so when battery time is an issue you should select “Long latency” at the cost of response time from the camera.

Always set the P+ back to “long latency” when the back is used in “two shoot mode” on a large format camera, i.e. a copal shutter or another mechanical shutter, where the shutter is released one time to wake up the back, and another time to capture the image.

While short latency will respond immediately to triggering the camera, Long latency although slower will give you with longer battery life.

P 40+ and P 65+ provides options of Normal or Zero Latency, Zero Latency will keep the CCD constantly powered, this should be avoided if not necessary.

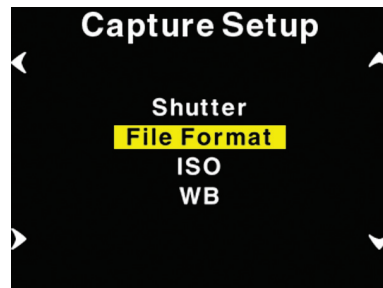

### FileFormat

In “FileFormat” you can select two options “IIQ Raw L” and “IIQ Raw S”.

“IIQ” is a short term for Intelligent Image Quality Raw.

“IIQ L” is set as the default and is the loss less capture format of the P+ back.

“IIQ S” is a smaller file, and not totally loss less in the format. The “IIQ L” is approximately 1/3 file size of the processed TIFF file. “IIQ S” is approximately 1/5 of the processed TIFF. Most users will use the “IIQ S” as there is virtually no quality difference between the two settings.

Please consult the camera specific sections in this manual to learn more about how to use shutter latency with your particular P+ back setup.

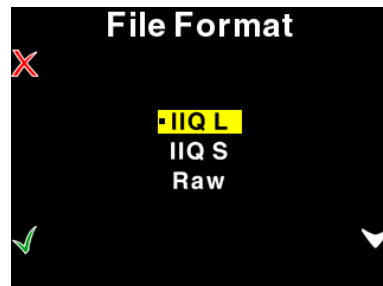



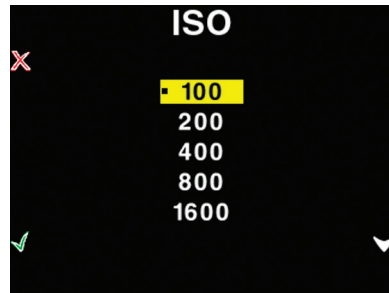

## ISO

In the ISO Menu choose from ISO 50 to ISO 1600 depending on the conditions you want (number of ISO options may vary depending on which model P+ back is used).

In general the higher ISO, the more noise in the image. This means that for optimal image quality, it is a better strategy to have more light in the scene or adjust the f stop on the camera, than just turning to a higher ISO.

When the preferred ISO setting is set press the “Enter” button to confirm the choice (green √ check mark).

Or if you regret the choice and just want to go back to the previous setting (the one with the little dot), select the “Exit” button (the red X).

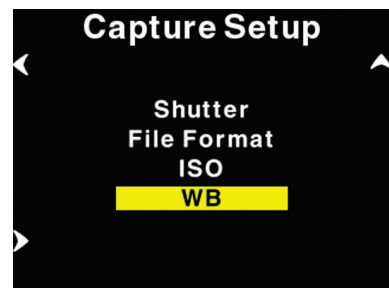

## White Balance

Setting Auto WB will calculate a white balance based on the information in the image. Auto WB is good for most applications.

If you are using a specific lightsource you can choose that option here.

If the camera back is tethered to a computer, and white balance is set from within Capture One it is indicated with the C1 icon in place of the WB indicator on the main screen.

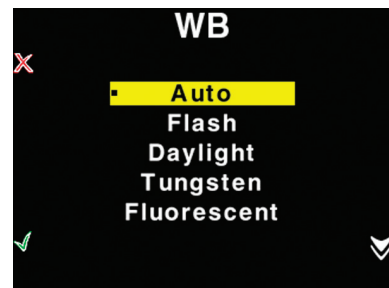

## Custom White Balance

Your P+ back allows you to create up to 3 custom white balances.

Custom WB is available when pressing the WB button at the main menu.

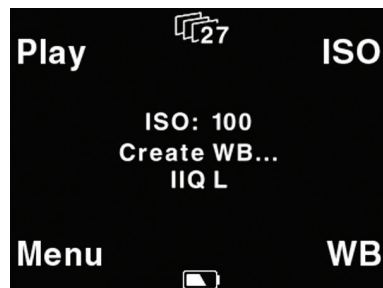

When scrolling to the bottom of the WB options four options are available:

“Custom1”, “Custom2”, “Custom3” and “CreateWB...”

To make a new custom white balance select CreateWB... and choose which one from the following: “Custom1”, “Custom2” or “Custom3”

When one of the options is selected the “Make Custom WB” will be blinking.

Now you are ready to capture the image that should be used for white balancing. Place the viewfinder center circle on an area (gray card or neutral white surface) and capture the image. You have now made the custom white balance and it has been set as the current capture white balance.

All subsequent captures will now have the new custom white balance applied.

3 different custom white balances can be defined and used as shooting white balances.

### Custom white balance from Capture One

You can also choose to easily transfer a white balance from Capture One to the P+ back:

1. Create a custom white balance inside Capture One.
2. While tethered to the computer select WB from the lower right button on the P+ back.
3. Select “Custom1”, “Custom2” or “Custom3” on the P+ back depending on where you want to store the new white balance.
4. Finally Click the “Set as capture white balance” button inside capture One.



The P+ back will beep to confirm that the custom white balance is uploaded, saved and ready to be disconnected.

This technique is useful because you can bring up to three predefined custom white balances taken in the studio to your location shoot.

Please be aware that when shooting tethered to the computer, the white balance must still be set in the Capture One application. White balance cannot be set on the P+ back while tethered.

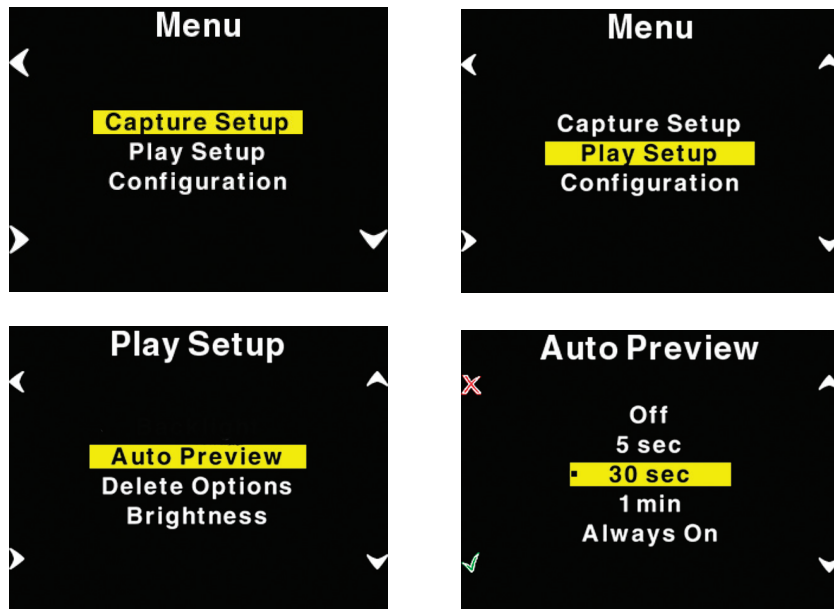

#### Notice

- If a button is touched during the auto preview period, the preview will remain on and the time-out will be disabled until next capture.

#### Play Setup

The second option in the menu mode is Play Setup.

Inside "Play Setup" you can select between "Backlight", "Auto Preview", "Delete options" and "Brightness".

#### Auto Preview

The second option in "Play Setup" is "Auto Preview". "Auto Preview" refers to the time the image is remains on the screen after capture.

If Auto Preview is set to "Off" the preview will not be shown automatically when a capture is taken.

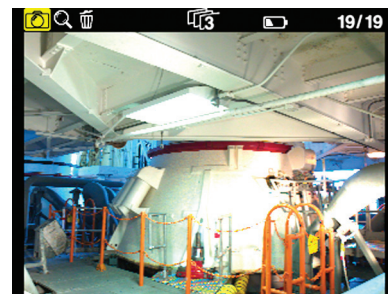
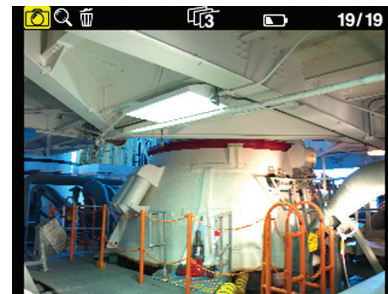
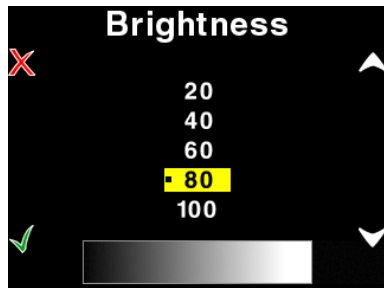
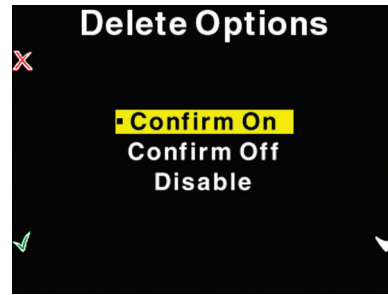

### Delete options

There are three delete options: “Confirm On”, “Confirm Off” and “Disable”.

In Delete options you can setup whether you want an extra confirmation when you delete images (Confirm On - Default), delete images immediately (Confirm Off), or you can disable deleting of images on the P+ back to avoid unintended loss of images.

### Brightness

In the Brightness setup, you can set the brightness of the preview LCD screen

Default setting is Bright.

Only the Brightness of the display is affected. Exposure warning, histogram and final capture is not affected by this setting.

A brighter display is helpful when you are outdoors with a lot of ambient light or shooting low-light images.

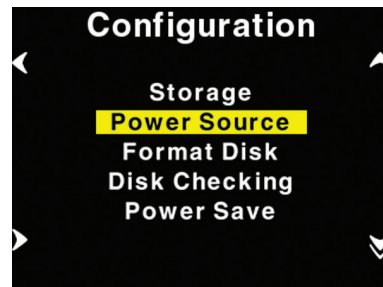
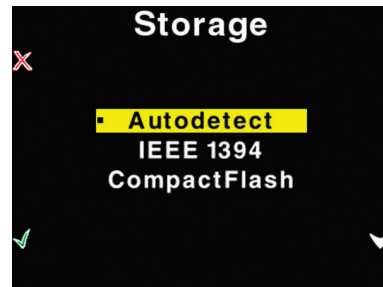
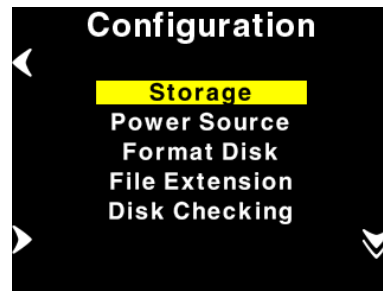

### Configuration

“Configuration” is used to setup general settings and perform general tasks on the P+ back.

“Configuration” contains more menu entries than can be displayed on one screen. This is indicated by a double arrow pointing down on the right side.

Scrolling past the last menu entry will reveal the next entry. Now the arrow in the top right side will turn into a double arrow, to indicate that there are hidden entries at the top.

### Storage

“Storage” is as default set to “Autodetect”. If a card is inserted in the P+ back it will automatically capture to this card. If not, it will capture via the IEEE 1394/FireWire port directly to the computer. If a card is in the back at the same time as the back is connected by FireWire to a computer, the FireWire will have priority to the CF-card.

If the P+ back is not tethered to a computer you will get an error message that the card slot in the P+ back is empty.

The P+ back can also be forced to shoot to either Compact Flash or IEEE 1394/FireWire by selecting the options inside “Storage”.

### Power Source

Power source only has two options, “Autodetect” or “Battery”.

In Autodetect, the P+ back will detect if an IEEE 1394/FireWire connection is supplying power, and automatically shut of the battery power.

If Power Source is set to “Battery” the power source is forced to come from the battery, and the digital back will not consume power from the FireWire connection.

This is especially useful to avoid draining the battery in a MacBook or PowerBook.

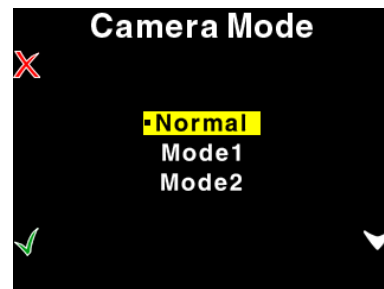
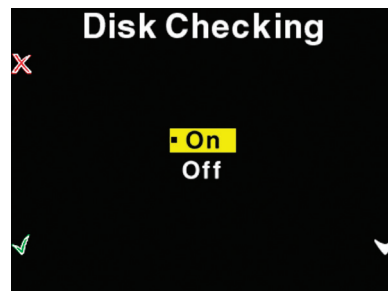

### Format disk

Selecting “Format disk” will erase the CF-card in the P+ back. The CF-card will be formatted as FAT-32.

Please see CF-card section for troubleshooting if your card is not recognized.

### File Extension

Decide the file extension to be either IIQ or TIF, this will merely affect the extension of the file, not the format.

### Disk Checking

Disk Checking is done per default on every card inserted to the P+ back.

If for some reason this check is not wanted the feature can be turned off in this menu.

Phase One recommends leaving disk checking turned on to maximize data security on memory cards.

Read more about the Phase One Secure Storage system in the user guide referring to your digital Phase One back.

### Camera Mode

Camera mode is used in special applications only. This could be in combination with a specific electronic shutter or in an industrial application, where the timing differs from a normal photographic application.

Please consult the documentation included with these solutions, to find out which mode to use.

If you are using the P 40+ or P 65+ back in a normal photographic application using medium format camera or technical camera as described in this manual, please leave this setting in “Normal” position.

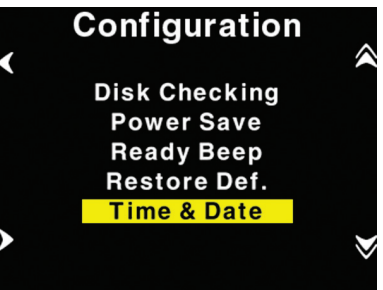
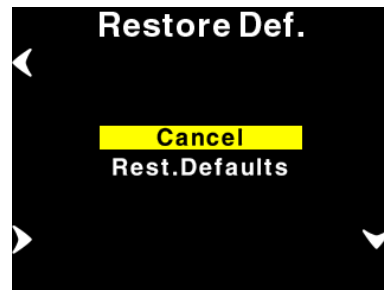
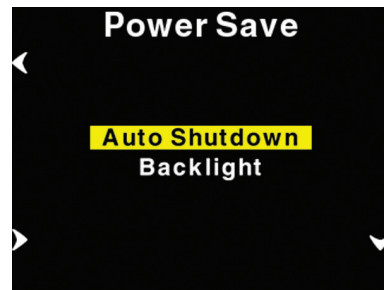

### Power Save

Power Save only has two options “Auto Shutdown” and “Backlight”.

Auto Shutdown is used to set the time frame before the P+ back Shuts down, when there is no activity.

If the P+ back is automatically shut down it can only be woken up by pressing the “Power” button.

### Ready beep

“Ready beep” is the small beep that sounds from the back when ready for a new capture.

The “Ready beep” signals that the P+ back is ready for next capture. “Ready beep” can be either “Single”, “Multi” or “Off”. Default is “Single”

“Multi” is for use in noisy surroundings, i.e. where it can be difficult to hear if it was the back or the flash that made the ready beep.

### Restore def. (Defaults)

Selecting restore defaults will restore the settings of the P+ back to its default settings. Be careful before using this option as all settings made in the P+ back will be reset to factory settings.

### Time & Date

In “Time & Date” you can set the time and date using the four buttons on the P+ back. Left side buttons will step through the hours, minutes and seconds field, while the right up and down buttons can be used to set the value of the fields. The time and date is applied to all files captured with the P+ back.

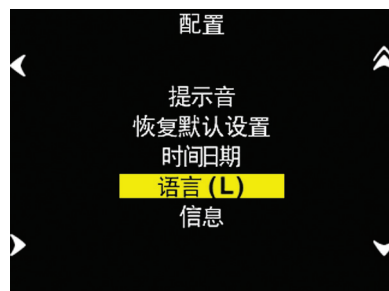

## Language

The “Language” option in the “Configuration” Menu can be used to select preferred language of the user interface.

Expressions in the main menu like: ISO, WB, Play and Menu are not translated.

These are regarded as icons, and also understood widely as expressions used to navigate even on the Japanese or Chinese interface.

However switching to an unknown language unintentionally can be frustrating and the user can have difficulty getting it back to the native language back on the menu.

Phase One has made this easy by incorporating a large “L” in a parenthesis after the Language menu.

Finding this “L” will help the user get native language back.

Currently (When this manual was written) the following languages are supported on the P+: English (default), Japanese, Chinese (Simplified), French, Italian, German and Spanish.

If there is sufficient request for more languages, these might be made available through a Firmware upgrade.

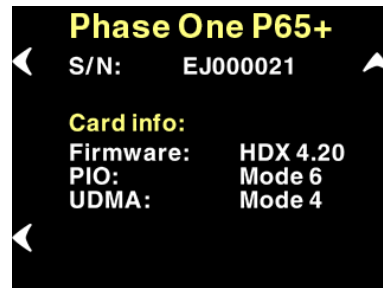
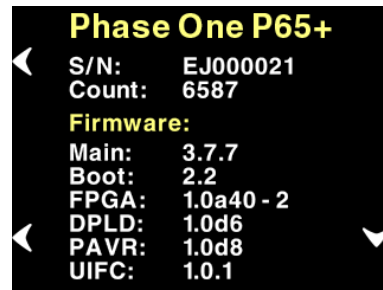

### About the P+ Back

The “About” option in the “Setup Menu” displays technical information about the hardware and embedded software (“Firmware”) in the camera. This is especially useful if support is needed or if you want to check if Phase One is offering a newer firmware for your camera.

Firmware might be made available in the download section at [www.phaseone.com](http://www.phaseone.com)

Before contacting your dealer or Phase One Support please make sure to have access to the “About” box or write down the entire contents of the “About” box.



## 7.0 Custom function

Custom functions provides options to change the method for using or accessing the camera functions. The custom functions can store separate settings for 3 users. When at C-00, chose 1 (A), 2 (B), or 3 (C) to store a specific set of user function selections for the group of custom settings from C-01 to C-19.

However, the C-00 is set to 0, the settings used will be the default set.

### Setting custom functions

1. Turn on the power.  
Turn the shutter release mode lever to the “S” or “C” position.
2. Turn the exposure mode dial to select “CF” (Custom Function mode).
3. Turn the rear dial to select the settings for user A, B, or C.
4. Turn the front dial to select the item you want to set.

### Clear all Custom Functions

Set mode dial button to CF, then press +/- button for 5 seconds, this will reset ALL Custom Functions to factory default

Seting custom functions to default

1. By turning the exposure mode dial, “CF” (custom function mode) can be selected.
2. By turning the rear dial, user “A”, “B” or “C” can be selected.
3. Press and hold down set button **A** (for longer than 1 second) and settings for A,B,C can be initialized, or the settings can be returned to “default”.

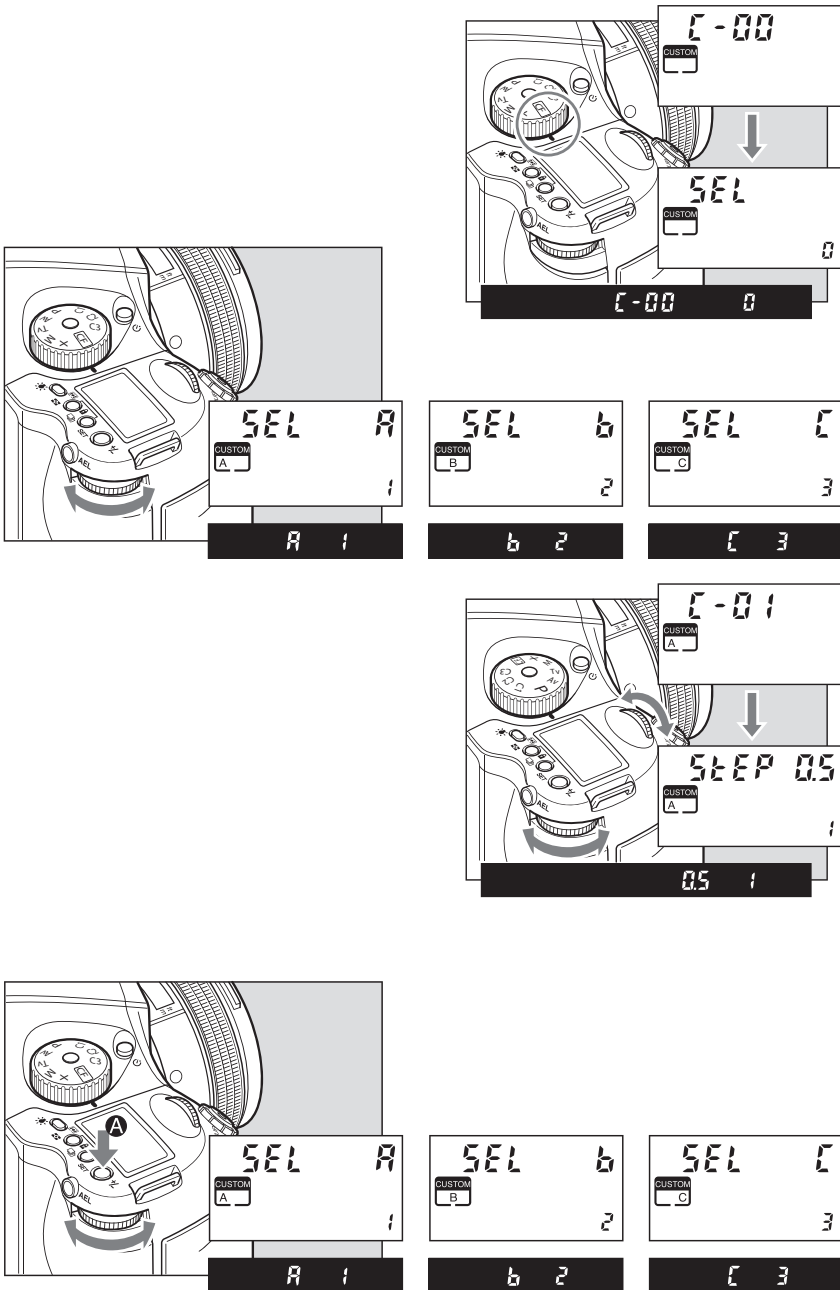



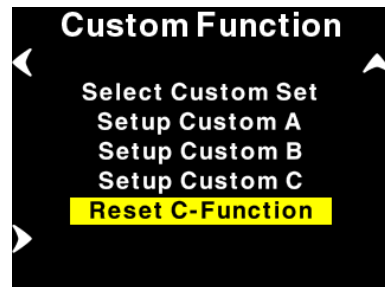
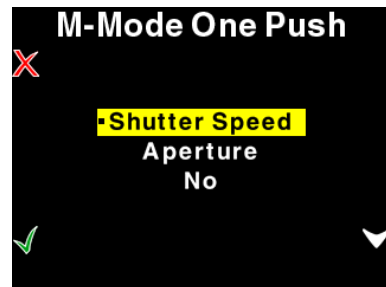
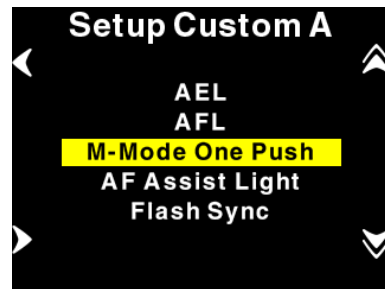
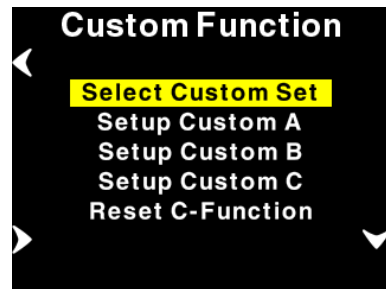
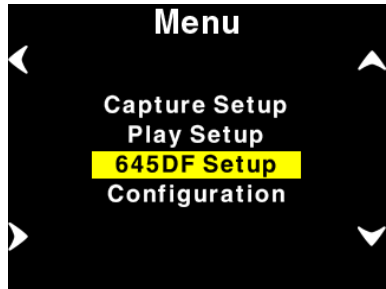

## 7.1 Custom Functions via P 40+ and P 65+

If your Phase One 645DF is equipped with a P 40+ or P 65+ back it is possible to select and adjust the Customs Functions via the back.

Enter the Custom Functions menu by selecting Menu>645DF Setup, this menu will allow you to adjust Custom Functions.

Firstly select the Custom Function user you wish to adjust.

Next choose to Setup the Custom Function.

You can adjust all adjustable custom function on the back, just like on the camera, but the back offers better explanation for the individual custom function, this will make selecting the custom function easier.

The functions are not numbered, but listed exactly as on the cameras top display, and this user guide.

## 7.2 Types of custom functions

### C-00 Custom functions profile [SEL]

0: Last used (default=0)

1: A

2: B

3: C

When “0” has been selected and set, none of the custom items can be set.

### C-01 Steps of aperture, shutter speed, exposure compensation. [StEP]

This function is used to set the size of increments concerning the shutter speed, f-number and exposure compensation value.

0: 0.3 (1/3EV step: initial setting)

1: 0.5 (1/2EV step)

2: 1.0 (1EV step)

### C-02 Aperture setting after lens change [IrIS]

This function is used to set the f-number display method for the previously used lens when the lenses have been interchanged. The default setting is “0” in which case the f-number of the lens prior to the changeover is displayed.

0: Previous f-number

1: Aperture open

2: Minimum aperture setting

### C-03 Time to sleep [HOLd]

This function is used to set the time for sleep mode to be established after the camera’s power is turned on. The default setting is 15 seconds.

0: 15 seconds

1: 30 seconds

2: 60 seconds

3: ON

The batteries will continuously lose power when “On” (no sleep mode) has been set.

### C-04 Select battery [batt]

This function is used to set the batteries used in the camera so that the remaining battery charge will be displayed correctly on the external LCD panel.

0: Alkaline

1: Ni-CD, Ni-MH

2: *for future use*

### C-05 Auto bracketing steps [Stno]

Setting bracket’s width for auto bracketing setting

0: 3 Exposures

1: 5 Exposures

2: 7 Exposures

### C-06 Front/Rear dial function exchange in manual mode [dF]

This function is used to interchange the functions of the front and rear dials in the M (manual mode).

0: Front dial: TV, rear dial: Av [OF]

1: Front dial: AV rear dial: Tv [On]

### C-07 Disable rear dial in P mode [d\_AC]

Initializing the P mode on the rear dial then changing the function to the front dial will cancel out P mode function on the rear dial.

0: No

1: Yes

### C-08 Direction of dials [d\_dl]

This function is used to determine the direction in which the electronic dial is to be rotated to increase and decrease shutter speed, the f-number, and exposure compensation.

0: Default setting (CW: Decrease) [OF]

1: Switched (CW: Increase) [On]

### C-09 AEL & AFL function button exchange [AEFL]

This function is used to set whether to interchange the operations of the front and rear AEL and AFL buttons.

0: Default setting (front: AFL, rear: AEL) [OF]

1: Switched (front AEL, rear: AFL) [On]

### **C-10 Half-press shutter release function mode [HALF]**

This function is used to set the AE lock and AF operations when the shutter button is half-pressed.

- 0: AF operation (default setting)
- 1: AF operation/AE lock
- 2: OFF (no function)

### **C-11 AEL function lock/unlock mode [AEL]**

This function is used to set the method of operating the AEL button to lock AE. At the default setting, when the AEL button is pressed, AE is locked; pressing the button again releases the AE lock. At the “1” setting (released after one shot), after AE lock is set, it is released when the shutter is triggered. At the “2” setting, AE lock is only kept while the AE lock button is being pressed.

- 0: Continuous
- 1: One shot
- 2: While the shutter button is pressed

### **C-12 AFL lock mode setting [AFL]**

This function is used to set the AF lock method when the AFL button is operated. AF >< Lock is activated with one press of the auto-lock button then deactivated with a second press.

- 0: Set with AF lock only (default setting)
- 1: AF operation
- 2: Continuous

### **C-13 One push M-mode [OnEP]**

When using M (manual mode) one push shift function, the shutter speed or aperture value can be set.

- 0: Shutter speed shift [tv]
- 1: Aperture value shift [Av]
- 2: No [no]

### **C-14 AF beam setting [AF\_L]**

The AF auxiliary light fires automatically when the subject is too dark to perform AF, but this function can be used to prevent the AF auxiliary light from firing.

- 0: Yes [On]
- 1: No [OF]

### **C-15 Flash sync. timing [FLSY]**

When shooting moving subjects with flash you can set the synchronization timing. This allows you to have the flash fire at the beginning of the exposure or at the end of the exposure.

- 0: Front curtain synchronization (default setting)
- 1: Rear curtain synchronization

### **C-16 Beep [bu]**

When the SET button is pressed a beep sounds

- 0: ON (AF) (Default setting)
- 1: ON
- 2: OFF

### **C-17 Choose shutter function Program mode [Sh\_P]**

When using P, Av or Tv mode and the leaf shutter lens is attached but you prefer to use the focal plane shutter.

- 0: Mixed. Default (Focal Plane shutter operation at < 1S)
- 1: Leaf shutter
- 2: Focal plane shutter

### **C-18 Choose shutter function (when in M mode) [Sh]**

When initializing the setting, use of the lens shutter (and its respective ranges) or the focal plane shutter can be chosen when the leaf shutter lens is attached.

- 0: Mixed. Default (Focal Plane shutter operation at < 1S)
- 1: Leaf shutter
- 2: Focal plane shutter

### **C-19 AF Speed [AF\_2]**

Accuracy of auto-focusing priority (default setting) or speed priority can be decided.

0: High speed control  
(Aperture to f/ 8 is recommended when using this function.)

- 1: High accuracy control (default setting)  
recommended for lenses with long focal length

### C-97 Support for Mamiya ZD backs

This function should ONLY be activated when shooting on a Mamiya ZD back.

0: Default setting **NO** Mamiya ZD back on the camera body

1: Mamiya ZD back on camera body

### C-98 Lens firmware version

The current firmware version can be checked.

### C-99 Body firmware version

The current firmware version of the body can be checked.

## Liquid Crystal Display

Due to the limitations of the space and letters, words and letters on the LCD are abbreviated.

Display examples of the main LCD

<i>On</i>	→	ON
<i>OF</i>	→	OFF
<i>Err</i>	→	Error
<i>+</i>	→	+ (Plus)
<i>u</i>	→	Under
<i>o</i>	→	Over
<i>n</i>	→	Normal
<i>Loc</i>	→	Lock
<i>SELF</i>	→	Self Timer
<i>bulb</i>	→	bulb
<i>buSy</i>	→	Busy
<i>db</i>	→	Digital Back
<i>LS</i>	→	Lens Shutter
<i>CAP</i>	→	Capture
<i>rP</i>	→	Repeat
<i>TIME</i>	→	Time
<i>batt</i>	→	battery

Display examples in the custom function mode

<i>SEL</i>	→	Selection
<i>StEP</i>	→	Step
<i>IRIS</i>	→	Iris
<i>Hold</i>	→	Hold
<i>batt</i>	→	battery
<i>Shot No.</i>	→	Shot No.
<i>dF</i>	→	Dial function
<i>d.AC</i>	→	Dial action
<i>d.dI</i>	→	Dial direction
<i>REFL</i>	→	AE, AF lock
<i>HALF</i>	→	Half press
<i>REL</i>	→	AE lock
<i>RFL</i>	→	AF lock
<i>OnEP</i>	→	One-push exposure
<i>RF.L</i>	→	AF assist light
<i>FLSY</i>	→	Flash sync
<i>bu</i>	→	Buzzer
<i>Sh.P</i>	→	Shutter in Program
<i>Sh</i>	→	Shutter in Manual
<i>RF.2</i>	→	AF second mode

## Custom Functions overview

No.	Item	Initial setting (0)	1	2	3
C-00	Custom Function User	Last used	User A	User B	User C
C-01	Steps of aperture, shutter speed, Exposure compensation	0.3 1/3 EV step	0.5 1/2EV step	1.0 1 EV step	
C-02	Aperture setting after lens change	Previous aperture value	Open	Minimum	
C-03	Time to sleep	15 sec	30 sec.	60 sec.	ON
C-04	Battery type	Alkaline	NIMH or NiCD	Future feature	
C-05	Auto Bracketing steps	3	5	7	
C-06	Front/Rear dial function exchange in manual mode	Front: TV Rear : AV	Front:Av Rear :Tv		
C-07	Disable Rear dial in P mode	Yes	No		
C-08	Dial Function direction	No switching	Switched CCW : Increase CW : Decrease		
C-09	AEL & AFL button exchange	Front: AFL Rear : AEL	Front: AEL Rear : AFL		
C-10	Shutter half-press function	AF operation	AF operation & AE Lock	OFF (no function)	
C-11	AEL function lock/unlock mode	Continuous	One shot	While the shutter button is pressed	
C-12	AFL lock mode setting	Set with AF lock only	AF operation	Continuous	
C-13	One push function M-Mode	Shutter speed shift	Aperture value shift	Off	
C-14	AF assist beam	Fires	Does not fire		
C-15	Flash sync. timing	Front Curtain	Rear Curtain		
C-16	Beep	ON (AF)	ON	OFF	
C-17	Choose shutter function (P, Av or Tv mode)	Mixed. (When inside the range of the leaf shutter lens)	Only Leaf shutter	Only Focal plane shutter	
C-18	Shutter function in Manual mode	Mixed. (When inside the range of the leaf shutter lens)	Only Leaf shutter	Only Focal plane shutter	
C-19	AF Speed	High Speed mode	High accuracy mode		
C-97	Mamiya ZD digital back support	<b>NO</b> Mamiya ZD back	Mamiya ZD back		
C-98	Lens Firmware version				
C-99	Body Firmware version				

### 7.3 Custom Dial Modes C1, C2 or C3

Mode dial options “C1”, “C2” and “C3” can be used to store preferred settings.

These settings can be changed instantly to suit the photographer's needs, you can change the settings on the camera body, or even easier on the back if you are working on P 65+ or P40+.

Programmable settings are exposure mode, “P” (program AE), “Av” (aperture priority AE), “Tv” (shutter speed priority AE), “X” (synchro mode), “M” (manual mode), focus area and spot metering.

#### Programming the Custom Dial Modes C1, C2 or C3 via the camera body

1. Go to the setting you wish to assign to “C1”, “C2” or “C3”.
2. After arriving at the setting you wish to assign, hold the SET button down while turning the mode dial to “C1”, “C2” or “C3”. When you release the SET button, the chosen setting will be programmed to your selection of “C1”, “C2” or “C3”.

“C1”, “C2” or “C3” modes can be changed while photographing. However after taking a photo in a mode other than the modes selected in “C1”, “C2” or “C3”, when you turn the dial back to a C mode setting the change will not be saved.

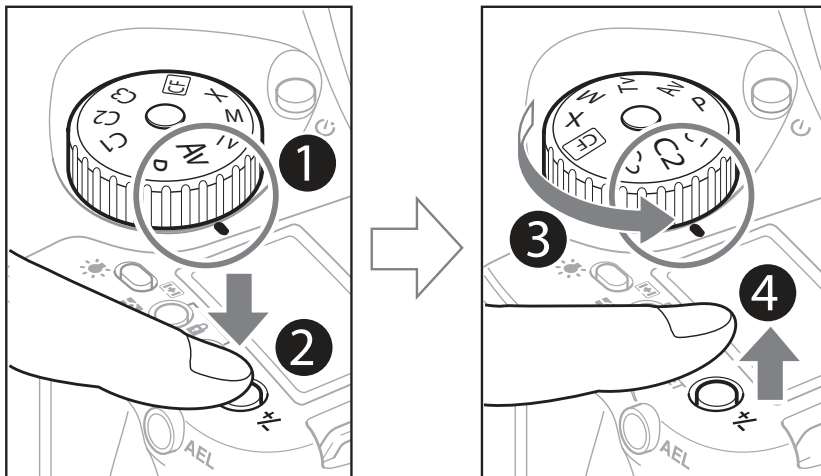

\* The illustration shows the exposure mode “Av” (aperture priority AE) being recorded to C2.

#### NOTICE:

Even when the power is switched off, the mode recorded will still be saved to C mode.

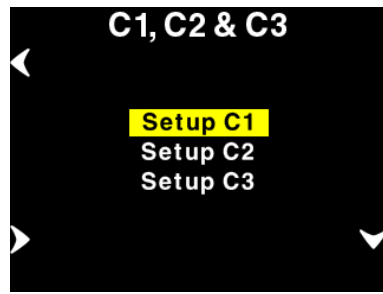

## Programming the Custom Dial Modes C1, C2 or C3 on the digital back

If your Phase One 645DF is equipped with a P 40+ or P 65+ back you can adjust control the custom dial modes via the back.

You can enter the custom dial modes menu by selecting Menu>645DF Setup, this menu will allow you to adjust custom dial modes (C1, C2, C3).

After selecting Setup C1, C2 or C3, you can choose to enter variables on Camera Mode (P, AV, TV, M, X), Auto Focus Area, Light metering and Custom Function profile.

After adjusting the settings leave the Setup menu, the adjustments are automatically stored, and transferred to the camera body

## 8.0 Lenses and Multi Mount

Phase One provides the widest range of possibilities, when it comes to lenses, this increases the possible creative solutions for the photographer, This chapter looks at some possible lens systems, but it is worth noticing that there are more applicable lenses available than there are presented here. The enthusiastic user can find loads of information on the internet and via dedicated Phase One dealers on items such as mount-adaptors, like the Phase One Multi-Mount.

Please note, errors or damage caused by third party products are not covered by the warranty, test new products with caution.

### 8.1 Functions of the Phase One lens

The Phase One 80mm f/2.8 is a sharp and well tested digital lens. The lens is mounted by aligning the white dot on the lens with the white dot on the camerabody, carefully mount the lens by turning it clockwise, until a click is heard, if you feel resistance or if you hear a scratching-like sound stop and retry – NEVER use force when mounting the lens, it should always slide into place without resistance.

The lens has 2 rings, the inner ring provides the possibility of changing the focus mode without changing grip of the body, keep the focus selector on the camera body on either “S” or “C” to decide whether focusing single or continuously, and decide whether to use autofocus or manual focus on the inner ring of the lens.

The focus ring is the outer ring on the lens, use this ring to manually set the focus, read more on focusing in the chapter 3.4 regarding autofocus.

[Read more on 3.4](#)   [Focus modes on page 30](#)

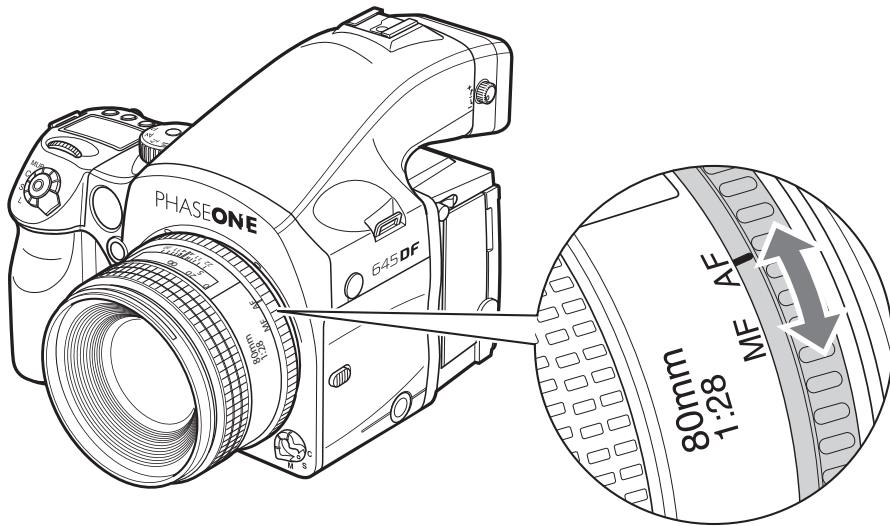

#### Notice:

If you select MF on the camera body, you might have to turn the camera off before the autofocus will start.



## 8.2 Function of the Phase One lens adaptor

To mount the Phase One Multi-Mount, match the white dot on the camera up with the white dot on the Multi-Mount and turn slowly clockwise, **NEVER** use force to mount the ring. When the Phase One Multi-Mount is mounted you can fit Carl Zeiss/Hasselblad V and Hasselblad 200series lenses on the camera.

### 8.3 List of alternative lenses

#### Recommended digital lenses

Producer	specs	limitations	adaptor/mount	notice
Mamiya	28 f.4,5 AFD		Mamiya 645AFD	Sekor
Mamiya	75-150 f.4,5		Mamiya 645AFD	Sekor
Mamiya	35 f.3,5		Mamiya 645AFD	
Mamiya	45 f.2,8		Mamiya 645AFD	
Mamiya	55 f.2,8		Mamiya 645AFD	
Mamiya	150 f.3,5		Mamiya 645AFD	
Mamiya	210 f.4,0		Mamiya 645AFD ULD	
Mamiya	300 f.4,5		Mamiya 645AFD APO	
Mamiya	55-110 f.4,5		Mamiya 645AFD	
Mamiya	105-210 f.4,5		Mamiya 645AFD ULD	
Schneider Kreutnach	55 f.2,8		Mamiya 645AFD	Leafshutter
Schneider Kreutnach	80 f.2,8		Mamiya 645AFD	Leafshutter
Schneider Kreutnach	110 f.2,8		Mamiya 645AFD	Leafshutter

Producer	specs	limitations	adaptor/mount	notice
Recommended MF lenses				
Mamiya	A 500 f.4,5	1+2	Mamiya 645	MF
Mamiya	A 300 f.2,8	1+2	Mamiya 645	MF+APO
Mamiya	A 200 f.2,8	1+2	Mamiya 645	MF+APO
Mamiya	55	1+2	Mamiya 645	leafshutter
Mamiya	80 f.2,8 N/L	1+2	Mamiya 645	leafshutter
Mamiya	150 f.3,8 N/L	1+2	Mamiya 645	leafshutter
Mamiya	105-210 f.4,5	1+2	Mamiya 645	
Mamiya	500 f.5,6	1+2	Mamiya 645	
Mamiya	55-110 f.4,5 N	1+2	Mamiya 645	
Mamiya	150 f.2,8	1+2	Mamiya 645	
Mamiya	300	1+2	Mamiya 645	
Mamiya	24 f.4,0	1+2	Mamiya 645	
Mamiya	35	1+2	Mamiya 645	
Mamiya	150 f.3,5 N	1+2	Mamiya 645	
Mamiya	45	1+2	Mamiya 645	
Mamiya	210 N	1+2	Mamiya 645	
Mamiya	80 f.1,9	1+2	Mamiya 645	
Mamiya	55	1+2	Mamiya 645	
Mamiya	80 f. 2,8 N	1+2	Mamiya 645	

Hartblei	MC TS-PC 45 f. 3,5		mamiya/Pentacon six	super-rotator tilt/shift
Hartblei	MC Hartblei 2x converter		pentacon six	

Producer	specs	limitations	adaptor/mount	notice
Arsat	MC Arsat 30 f.3,5 fisheye		Pentacon six	
Arsat	MC Arsat 45 f.3,5 Wide Angle		Pentacon six	
Arsat	MC PCS Arsat 45 f.3,5		Pentacon six	shift
Arsat	MC PCS Arsat 55 f.4,5		Pentacon six	shift
Arsat	MC PCS Arsat 65 f.3,5		Pentacon six	shift
Arsat	MC Arsat 80 f.2,8		Pentacon six	
Arsat	MC Arsat 600 f.8,0		Pentacon six	Mirror

#### Lenses usable in combination with Phase One Multi-Mount

Carl Zeiss	CFi 30 f.3,5	3	hasselblad V	
Carl Zeiss	CFE 40 f.4,0	3	hasselblad V	
Carl Zeiss	CFi 50 f.4,0	3	hasselblad V	
Carl Zeiss	CFi 60 f.3,5	3	hasselblad V	
Carl Zeiss	CFE 80 f.2,8	3	hasselblad V	
Carl Zeiss	CFi 100 f.3,5	3	hasselblad V	
Carl Zeiss	CFE 120 f. 4,0	3	hasselblad V	
Carl Zeiss	CFi 150 f.4,0	3	hasselblad V	
Carl Zeiss	CFE 180 f.4,0	3	hasselblad V	
Carl Zeiss	CFi 250 f.5,6	3	hasselblad V	
Carl Zeiss	CFE 350 f.5,6	3	hasselblad V	SA

#### Special purpose lenses

Mamiya	120 f.4,0 MACRO		Mamiya 645	MF
Mamiya	50 SHIFT	1	Mamiya 645	MF
Mamiya	645 Auto bellows unit	1	Mamiya 645	
Mamiya	80 MACRO	1	Mamiya 645	

#### Other lenses usable in combination with adapter

Hasselblad	30			fisheye
Hasselblad	40			
Hasselblad	50			
Pentacon	flektogon 50			
Arsat	55mm Shift			
Biometar	80mm			
Biometer	120mm			
Sonnar	180mm			

#### Limitationcodes:

- 1: Stopped down metering not possible
- 2: Discontinued
- 3: Leaf shutter disables, only aperture priority

## 8.4 Lens Cast

### What is Lens Cast?

Lens cast may occur if using the camera back with wide-angle lenses e.g. Horseman Digiflex II, Hasselblad Flexbody or Hasselblad 905SWC or on other large format cameras with different tilt-or swing settings. On a medium format camera lens cast is very rare if using fixed lenses from 60 mm to 120 mm.

### Why does lens cast occur?

Lens cast occurs as a result of the angle at which the CCD is exposed to light. If the CCD is exposed to light coming from a very sharp angle e.g. wide-angle or extreme degrees of tilting you may experience lens cast.

### What does it look like?

Depending on the light conditions and photographic setup, lens cast can appear differently. On some lens/back combinations there will appear to be a color transition from green-ish to magenta-ish, from one side to the other across the entire image, displaying many different colors. If you want to test your lens for color cast, take a photo of a grey wall or cardboard, and check the image for “false” colors.

### How to get rid of Lens Cast?

If working with large format cameras with tilt and swing, it is necessary to make a new calibration file if the tilt and swing position is changed. Phase One provides a solution in the Capture One software that helps removing the lens cast, called Lens Cast Calibration (LCC)

By holding an opaque white plate in front of the lens it is possible to capture a calibration image. The image can be used in Capture One to create a so-called LCC profile which can be applied to any images captured in the same light and lens to remove the lens cast.

On medium format cameras the calibration is very simple: You do one calibration for each lens and then save the calibration files and apply them when needed by toggling “Set as default for new Captures”.

### 8.5 4 simple steps to calibrate on fixed lenses (MAC)

1. Hold the calibration plate in front of the fixed lens (as close as possible), and capture. In order to ensure correct exposure you may have to up a few f-stops or in a very dark setup, put on more light directly onto the plate.
2. In the Capture One software you select the 'calibration' image and click on the "Save LCC" button (the LCC tool is located in the Lens tab).
3. Give the calibration file a name that corresponds to the lens in use or the set-up (e.g. 45mmDaylight)
4. Select the calibration file: "45mm Daylight" from the "Lens CC" drop-down list and click "Set as default for new Captures".

### 8.6 Large format and stitched images (MAC)

Large format and stitched images (Mac)

When using LCC in combination with large format capture and image stitching you must capture one calibration file per image and make sure that you match the calibration file to the right image prior to stitching.

1. Start by capturing the two calibration files and the two image files.
2. Save the right-side calibration file by clicking the "Save LCC"
3. Name the calibration file i.e.CarsRight.
4. Save the left-side calibration file the same way.
5. Select the right-side image and apply the right-side calibration file. Select the left-side image and apply the left-side calibration file.
6. A simple way to gray calibrate is to select all images in the browser window. Click on the left-side center of the right side calibration file and apply that gray balance to all images by clicking the "Apply to all selected" (remember to only select apply gray balance in the dialog).

**PLEASE NOTE:** As soon as grey calibration is done and the calibration files are saved and appear in the LCC drop-down box the calibration files can be deleted from the thumbnail window.

### **8.7 4 simple steps to calibrate on fixed lenses (PC)**

1. Hold the calibration plate in front of the fixed lens (as close as possible), and capture. In order to ensure correct exposure you may have to open up a few f-stops or in a very dark setup, direct more light directly onto the plate.
2. In the Capture One software you select the 'calibration' image and click on the "Generate..." button (the LCC tool is located under the Lens tab).
3. Give the calibration file a name that corresponds to the lens in use or the set-up (e.g. 45mmDaylight)
4. Select the calibration file: "45mm Daylight" from the "Lens CC" drop-down list and set a checkmark in the "Apply LCC for next Captures".

If working with large format cameras with tilt and swing, it is necessary have to make a new calibration file if the tilt and swing position is changed.

When using LCC in combination with large format capture and image stitching you must capture one calibration file per image and make sure that you match the calibration file to the right image prior to stitching.

## 8.8 Large format and stitched images (PC)

1. Start by capturing the two calibration files and the two image files.
2. Save the left-side calibration file by clicking the “Generate...” button
3. Name the calibration file i.e.”CarsLeft”.
4. Save the right-side calibration file the same way.
5. Select the right-side image and apply the right-side calibration file. Select the left-side image and apply the left-side calibration file.
6. A simple way to white balance is to select all images in the thumbnail window and click on the left-side center of the right side calibration file and apply that white balance to all images by clicking the “Apply this White Balance to the current selection of captures”.



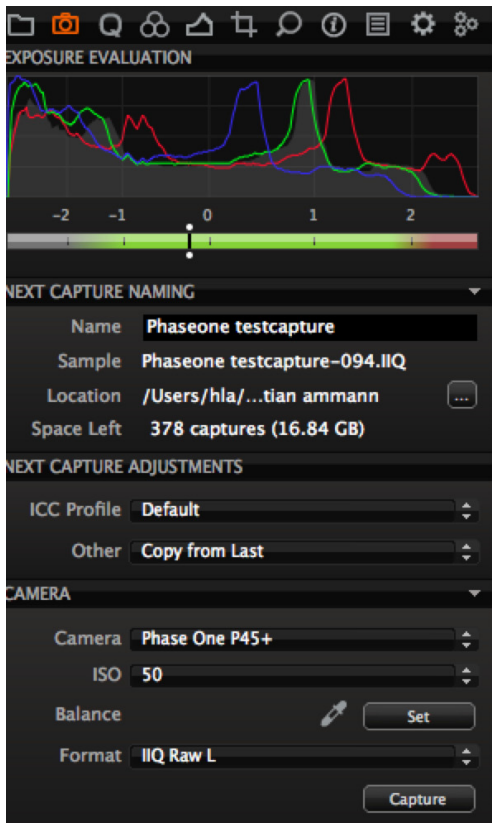

## 9.0 Software

Capture One, is a part of the new Phase One camera platform.

For further information regarding functions of Capture One 5 please read the users guide for this, the user guide is found under the help menu on Windows and Mac.

### 9.1 Getting started

The user interface of Capture One 5 is very close to Capture One 4, you will find the well known tabs Library, Quick, Color, Exposure, Composition, Details, Adjustments, Meta, Process and Batch, Capture and Lens tool; all new features is placed in the previous introduced tool tabs.

Read the software manual before using the software, and do test shots before using the software for professional use.



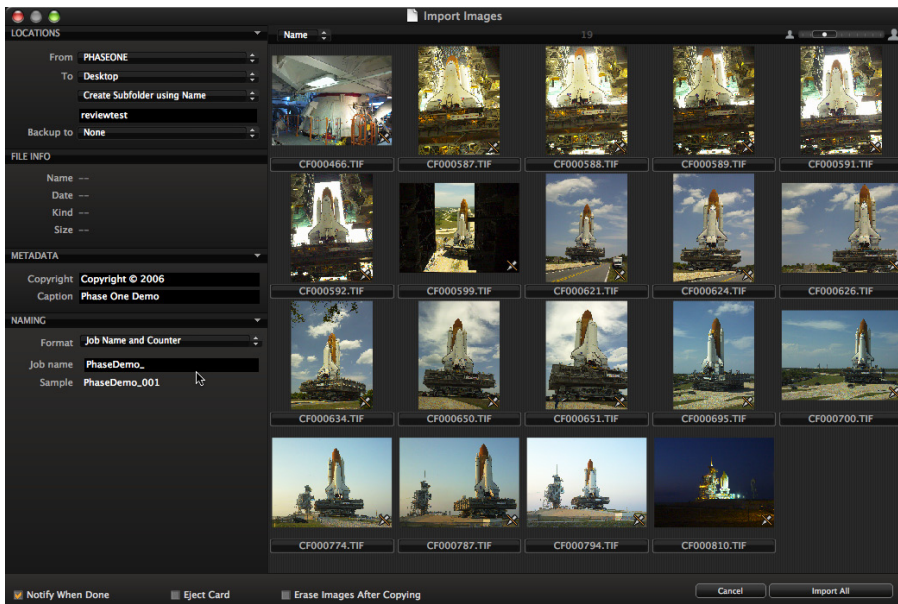

## 9.2 Importing from CF card

You can import images directly into your Capture One Session from a memory card inserted into a card reader. You can also easily browse to a disk containing RAW images on your local or network computer.

Choose File > Import images or select the import images button to begin the import process. Immediately, a large dialogue box appears showing a preview of files to be imported. This dialogue box also provides a range of options from which to choose.

Inserting a memory card into a card reader will automatically bring up the import dialogue window. The Import window offers a range of options to make importing a quick and straightforward task.

It is important to remember that you are importing images from one location to another. You need to create or define a folder to which the files will be imported to. This can be done manually or through the Locations tab in the file importer window.

Capture One can automatically create subfolders, named by date or user defined. When importing you can also choose to rename the files, as they are imported from the camera or cd/memorycard, the file names can be changed by double-clicking on the filename in the browser or when exporting the files.

## **10.0 Large format and technical cameras**

Phase One's status as open platform does not only mean the possibility of fitting the back on different medium format cameras, but also large format and Technical cameras.

### **10.1 Large format photography**

With the Phase One back you can use your large format camera to capture digital images.

As the light sensitive chip in the P-back is not (yet!) 4x5" or 8x10 you have to use an adapter to move the back to capture the entire view, the FlexAdapter is a sliding back used to connect a Phase One back to a large format camera. A ground glass is provided for initial set-up that slides over to position the digital back in the perfect orientation to the focused area.

Markings are provided for the stitching function which allows two captures to be taken, beside each other with a slight overlap. These marks can be used for later Stitching work.

The design is simple and clever, using a standard lens board mounted on the back of the adapter for specific large format systems. Currently there are versions for Sinar, Cambo, Arca Swiss, Linhof and Toyo systems. Large format cameras that use a lens board for mounting the ground glass assembly can be custom adapted (custom adaptation service not provided by Phase One). All Phase One camera solutions from the P 21+ to the P 45+ can be used with the FlexAdapter and all backs can provide stitched images.

- Please read the specific largeformat leaflets, and consult your local dealer, you will be amazed by the possibilities.

## 10.2 Technical cameras

The use of technical cameras is growing. Images taken with a technical camera can have a different look and feel compared to DSLR or medium format capture. The look is achieved through unique focal lengths, use of rise/drop and shift movements and a different optical point of view.

For many photographers, quality cannot be compromised. A technical camera provides significantly more optical quality especially when combined with a Phase One back and Capture One software. The optical path is straight and simple with no mirror systems to worry about. This removes the need of retro-focus design wide-angle lenses that compromise image quality with DSLRs and mediumformat.

Both Rodenstock and Schneider have produced technical camera lenses that are tuned to the capture area and quality requirements for digital photography. A technical camera solution offers the sharpest possible results.

For more information on technical photography consult your local dealer.

## NOTICE

Since the Focusing Screens' surfaces are soft and easily damaged, handle them carefully.

Never touch the surface with bare fingers. Should dust settle on it, merely blow away by using a blower.

If the Focusing Screen needs cleaning, send it to the nearest authorized Phase One service center.

Do not attempt to clean the surface of the Focusing Screen, as it is very delicate.

Do not touch and damage the mirror in any way.

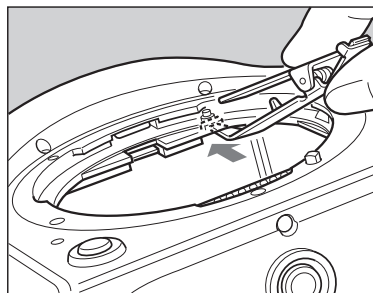
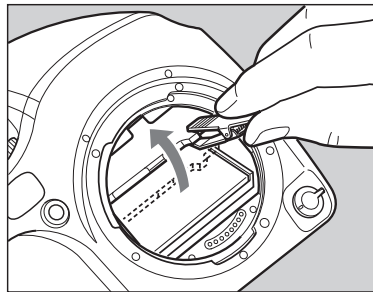
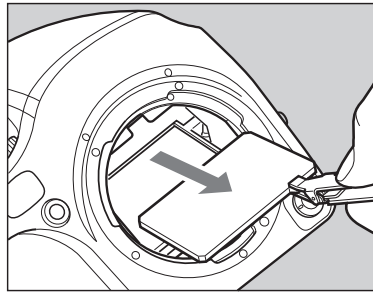
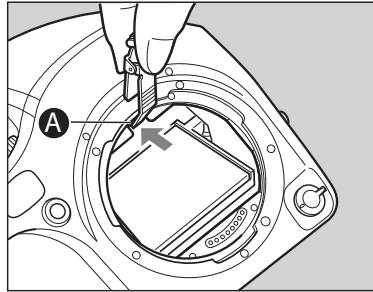

## 11.0 Maintenance

In general very little maintenance is needed, but this is a professional tool, and should be treated with care and caution. If the gear for any reason has not been used for a long period, you should always do test shots before the photographic session.

A frequently used product should be inspected periodically at the nearest official Phase One repair center. Should there be errors or malfunctions of camera, lens or back – do NOT try to repair – consult your local dealer.

### 11.1 changing the focusing screen

1. Remove the lens.
2. Pull the Focusing Screen Release lever **A** forward, as illustrated, with the tweezers to let the Focusing Screen down.
3. Remove the Focusing Screen from the Focusing Screen Frame by grasping the tab on the edge of the screen with tweezers as illustrated.
4. When installing the screen, pinch the tab of the screen with tweezers, and put the screen on the screen frame.
5. Push up the screen frame using the tweezers until hearing a clicking sound. The screen is now properly installed. - Never press down on other parts as this will affect the focus function.

**Notice:**

Make sure to re-install the empty battery case into the body.

The empty battery cassette must be inserted into the body.

The batteries may generate heat if the external battery case is connected to the body while the batteries are loaded on the body.

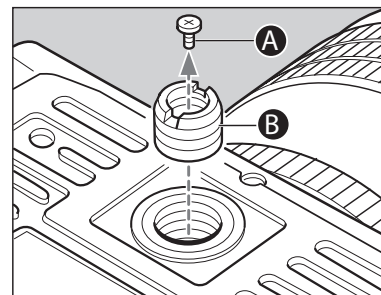
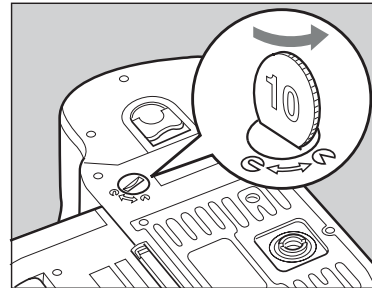
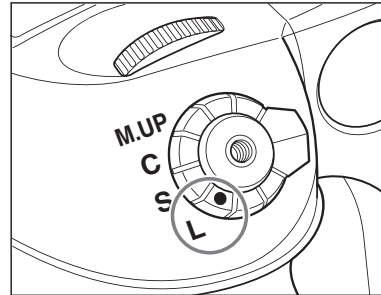
**11.2 Battery socket**

Never leave batteries in the socket, if the camera or back is not supposed to be used for longer periods.

Keep contacts clean and dry at all times.

**External battery socket**

When using the camera at cold temperatures where the battery capacity may drop, use an external battery case PE401

1. Turn the shutter release mode selector lever to the “L” position (power off).
2. Use a coin or similar object to turn and remove the external battery socket cap.
3. Remove the battery case from the camera body
4. Connect the external battery case to the body. Connect the plug of the external battery case in which the batteries are installed, to the external battery socket.
5. Reinstall the original battery case, from which the batteries were removed, in the body. Turn the battery case lock to lock it in the body.

**11.3 Tripod/Electronic shutter release contact**











Keep all contacts clean and dry at all time.

When using a tripod with 3/8” screw (instead of 1/4” screw) remove the small screw[A] from the tripod screw hole on the bottom of the body using a plus screwdriver, then use a coin to remove the tripod screw adapter bushing[B].

You will find Electronic shutter release both on the camera body and on the back. When used, it is recommendable to use the shutter release on the back. Keep both contacts dry and clean.

## 11.4 Camera display error-notification

### When Any of These Displays Appear

LCD display			Causes and remedies	
Main LCD panel	Viewfinder LCD read-outs	Magazine LCD	Problems	Remedies
	▶ ◀		<p>* If the camera cannot focus in the AF "S" (Single) mode, you cannot release the shutter.</p> <p>* When an M645 lens is installed and the aperture is less than f/5.6, this indicator appears.</p>	<p>- Try to adjust focus again, or change to the focus lock mode or manual focus mode.</p> <p>- Make the lens aperture faster than f/5.6.</p>
batt	 batt		<p>* This indicator appears when the battery capacity is low.</p>	<p>- Replace with new batteries.</p>
-no-db	 -no-db		<p>* The shutter will not operated when the digital back is not installed onto the camera body. If you try to press the shutter, this indicator appears.</p>	<p>- Install the digital back onto the camera body.</p>
			<p>* This symbol appears when setting the custom functions but you have not selected user A, B, or C.</p>	<p>- Select a user before changing the custom function settings.</p>
	- U - - O -		<p>* While in manual exposure mode, and when the difference between the set value and metered value exceeds 6EV, this indicator will appear.</p>	<p>- Change aperture or shutter speed.</p>
F -	 -		<p>* This will appear when a lens is not installed.</p> <p>* When an M645 lens is installed.</p>	<p>- Install a lens on the camera body.</p>
Err-01 Err-02 Err-03 Err-04 Err-05 Err-06 Err-07	      		<p>When "Err" appears, some abnormality has been detected in the course of taking photos.</p>	<p>- Replace with new batteries and press the shutter release button. If the "End" indicator still does not disappear, then contact our sales office or service center.</p>

★ The camera caution mark  will blink if the camera body detects an abnormality.

### **11.5 Lens maintenance**

Never touch the inner optics of the lens with your fingers, keep the inneroptics perfectly clean with air, lens brush or the dry cloth delivered with the lens.

Do not touch the contacts; keep the contacts clean, either by dry cloth or by using fiberglass brush, do not use tools of any kind on the lens.

The lens is not waterproof, if wet it should be dried with a cloth, if exposed to salt, moisten a cloth, wring it and clean.

### **11.6 Back Maintenance**

#### **Cleaning the CCD**

When the Phase One P+ back is not attached to a camera, the camera back must be protected with the protection plate. However, over time dust may accumulate on the IR filter. This will degrade the image quality if not removed.

Please follow the directions included in the CCD cleaning kit in the P+ back suitcase.

## 11.7 housing specification

**Camera type :** 6x4.5cm format, electronically controlled focal-plane shutter, TTL multiple mode AE, AF single lens reflex

**Actual Image size:** 56x41.5 mm

**Lens mount :** Mamiya 645 AF Mount, compatible with M645 Mount (manual focus confirmation, focus aid, stopped-down exposure metering)

**Viewfinder :** Fixed prism viewfinder magnification x0.71; built-in diopter adjustment (-2.5 to +0.5, optional diopter correction lenses provide adjustment ranges of -5 to -2 diopter and 0 to +3 diopter); built-in eye-piece shutter

**Focusing screen :** Interchangeable, Matte (standard), Checker, and Microprism Type C for Non-AF M645 lenses.

**Field of view :** 94%\* of actual image

**Viewfinder info :** Focus mark, defocus mark, warning mark, aperture value, shutter speed, metering mode (A, S, A/S), exposure compensation value (difference between set value and metered value) and flash ready/ OK lamp with TTL Metz connection.

**AF method :** TTL phase difference detection method; sensor: CCD line sensor (I+I type); operating range: EV0 to EV18 (ISO 100)

**Focus area :** Displays the focus area in the viewfinder screen

**AF assist beam :** Activates automatically under low light, low contrast.

**Range:** 9m (when using AF80mm f/2.8 D lens)

**AF lock :** By pressing the shutter release button halfway down in the AF-S mode, or by pressing the AFL button.

**Exposure modes :** Aperture-priority AE, shutter-priority AE, programmed AE (PH, PL setting possible), and manual

**AE meteringmode :** TTL metering, center-weighted average (AV), spot (S), and variable ratio (A-S auto)

**Increments of shutter :** Both the shutter speed and the aperture level can be set to 1/3 or speed and aperture 1/2 using the electronic dial lock function

**Metering range :** EV 2 to EV 19 (with ISO100 and AF80mm f/2.8 D lens)

**Exposure compensation :** Expandable to  $\pm 5$  EV

**AE lock :** With AEL button; canceled by pressing the button again. When AEL button is pressed, exposure compensation and metering difference is displayed in the viewfinder. (+-6EV, 1/3 steps in M mode).

**Shutter :** Electronically controlled vertical metal focal-plane shutter. (vertical travel)

**Shutter speed :** AE 30 to 1/4000 sec. (1/8 step), manual 30 to 1/4000 sec. (1/2 or 1/3 steps), 1 min-60 sec. (1 step), X, bulb (Bulb, electronically controlled), tIME, shutter curtain protection mechanism

**Auto bracket shot:** Enable with auto bracket button (3 frame shots, 5 frame or 7 frame shot with auto bracketing). Specify 1/3, 1/2, 2/3 or 1EV steps.

**Flash synch :** X contact point, 1/125 seconds. Synchro speed can be changed away from terminal.

**Flash control :** TTL direct flash control, supports Metz SCA3002 system (SCA3952 Adapter)

**Mirror up shot :** Select by pressing the mirror up button.

**LCD displays :** Program AE mode icon, synchro mode icon, shutter speed, aperture, custom function icon, user function icon, focal plane mode icon, lens shutter mode icon, AE lock icon, auto focus lock icon, mirror up icon, focus area icon, auto bracketing icon, self timer icon, repeat mode icon, delay mode icon, remaining battery power icon, spot metering icon, dial lock icon, flash compensation icon, exposure compensation icon, exposure compensation, delay time.

**Sync terminal :** X contact (sync speed 1/125 sec.)

**Cable release socket :** On shutter button

**Remote-control terminal :** On side of body; electromagnetic cable release RE401 and RS402

**Self timer :** Self timer intervals can be set from 0.5 to 90 sec.: 0.5-10 sec. by the second, 10 to 90 sec. in 10 sec. units, 2 to 10 mins by the minute and 10 to 6 mins in units of 10 minutes.

**Depth-of-field confirmation :** Preview Button on body

**Custom settings :** 19 items

**Tripod socket :** U 1/4 inch and U 3/8 included

**Power requirements :** 6 AA-size batteries (alkaline-magnesium, lithium, nickel-hydride or nickel-cadmium rechargeable batteries).

**External power socket :** An external battery case can be connected.

**Size & weight :** 6 "(W)X5 "(H)X6 "(D) / 153(W)X128(H)X152(D)mm  
2.3 pounds / 1,030 g (body only)

\* This information is based on a linear (horizontal/vertical) measurement.



## 11.8 P+ series Technical specifications

Please read the schedule for detailed overview of the different backs.

# The Phase One P+ Product Range



Illustration photo © Drew Gardner

	P 65+	P 40+	P 45+	P 25+	P 30+	P 21+	P 20+
	World's first full frame medium format digital back, featuring <b>Sensor+</b> with a choice of 60 megapixels for finest resolution or scaled full frame captures for fast workflow and low light versatility.	Fastest digital back with up to 1.8 fps in <b>Sensor+</b> mode. A choice of 40 or 10 megapixels and an ISO range from 50 to 3200 makes this digital back the most versatile tool in the range.	High resolution shooter with unlimited burst sequences and optimized for large format photography with live preview functionality for easy composition and focus checking	All-round shooter with unlimited burst sequences and optimized for large format photography with live preview functionality for easy composition and focus checking	The top quality fast fashion shooter with ISO 1600, with superior moiré control and well suited for harsh environments	The fast and flexible high-end DSLR alternative with high dynamic range, brilliant ISO 800 and unlimited burst capture. Very useful in large and wide angle photography, and well suited for harsh environments	The square format all-round studio portrait shooter with an attractive price tag. Optimized for 6x6 camera systems as well as large format photography
Lens Factor	1.0	1.3	1.1	1.1	1.3	1.3	1.4
CCD size effective (mm)	53.9 x 40.4	43.9 x 32.9	49.1 x 36.8	48.9x36.7	44.2 x 33.1	44.2 x 33.1	36.9 x 36.9
Active pixels	8984 x 6732	7320 x 5484	7216 x 5412	5436 x 4080	6496 x 4872	4904 x 3678	4080 x 4080
Pixel size (micron)	Full res. 6 x 6 <b>Sensor+</b> 12 x 12	Full res. 6 x 6 <b>Sensor+</b> 12 x 12	6.8 x 6.8	9 x 9	6.8 x 6.8	9 x 9	9 x 9
Resolution (Mega pixels)	60.5      15.0	40      10	39	22	31.6	18	16
Light sensitivity (ISO)	50-800      200-3200	50-800      200-3200	50-800	50-800	100-1600	100-800	50-800
Exposure time	1/10000 - 1 minute	1/10.000 - 1 minute	1/10.000 sec. up to one hour with XPose+ technology				
Image Quality	16bit-OptiColor+, 12 f-stops Dynamic+ and Lens+ technology						
Capture time (frames per second**)	1.0      1.4	1.2      1.8	0.67	0.67	0.8	1,25	0,87
Battery Lifetime (captures/ up to stand-by time*)	2000 / 3	2500 / 4	2500 / 4	4000 / 4	3000 / 3	5000	4500
Image buffer	1.3 GB High Speed RAM		640 MB high speed RAM				
Display	2.2" QVGA TFT with 230,000 pixels, high brightness and contrast both indoor and outdoor, very fine details						

Results are based on testing in Phase One's testing department. Variation may be expected due to specific camera set up. Battery used for test is new 2500mAh Li+.

\*) Standby Time will vary a lot depending on temperature, usage of battery and state of the back e.g. Zero Latency will increase power consumption significantly

\*\*\*) Maximum expected performance. The actual performance will be dependent on the camera model and on the camera and digital back capture modes

All specifications are subject to change without notice. # 86711700

PHASEONE

WWW.PHASEONE.COM

## **11.9 End User support Policy**

By purchase of a Phase One product we guarantee you World Class Support and Service!

Please check [www.phaseone.com](http://www.phaseone.com) for updated support policy

### **World Wide Dealer Network**

At Phase One we think globally but act locally. Phase One's products are sold through a world wide network of dedicated and competent local partners to make after-sales support convenient for you.

Phase One's local partners offer first line support to their customers. Many provide additional services such as training, extended warranty agreements, upgrade programs, and many other services that will add value to your Phase One investment. Contact your local Phase One partner to discuss your options. Digital camera back pricing and repairs are also handled locally.

If there is no local partner in your area, then please contact Phase One directly, and we will assist you directly or through one of our partners. Find your local Phase One partner or take advantage of Phase One's wide range of on-line support tools at <http://support.phaseone.com>.

## **FAQ, Tutorials & Documentation**

The FAQ is a collection of the most frequently asked questions and related answers in the Phase One Knowledge Base. Use the FAQ as the first and best place to find answers on many technical questions. If you are seeking more detailed information about Capture One, Portrait One, or our Digital Backs, you can download user guides and manuals or watch some of the tutorials available.

## **Knowledge Base**

Phase One's searchable Knowledge Base at <http://support.phaseone.com> provides you with detailed answers to most of your questions. This 'self-service' site is free of charge and available to all Phase One owners.

## **Capture One On-line Support Forums**

On Phase One's official support forum you may share your experiences and get assistance from other Phase One owners as well as from Phase One's Technical Support team. Some Phase One partners offer on-line support forums, hosted from their own web pages. Please note that these forums are governed by separate rules. Phase One offers no guarantees and assumes no responsibility or liability with respect to the support provided by our local partners.

## **On-Line Support**

You can contact Phase One Technical Support directly by creating an on-line support case on <http://support.phaseone.com>. Phase One Technical Support will do its best to answer your question as quickly as possible.



## COMPENDIUM - ADDITIONAL TEXTS

### TTL Flash photography on Phase One camera and Focal Plane shutter

TTL means it is through the lens, i.e. handled by the camera, and it should also be OTF (off the film plane) which means the camera measures and adjusts the light reflected from the film plane (in our case, the protection filter in front of the CCD) rather than simply measuring what comes through the lens. This is considered to be more accurate.

If you use M or X, then you are simply setting an aperture and the flashgun is handling the flash fill. In this setup there is no need for the SCA adapters, just set the flash on auto. This can be done with a variety of flashguns.

When using TTL flash photography the amount of light is controlled by the flash unit itself. The camera is measuring the light from the flash (reflected off of the subject). It then gives the flash instructions on when to stop the flash pulse. It is important to remember that there are some limitations when using TTL flash, as the camera is only metering for neutral gray. If your scene/subject is darker overall the camera will instruct the flash to compensate and expose for far too long resulting in an overexposed image.

- The OTF sensor can be seen when removing the back from the camera system (and the shutter is in open position) you can see a small sensor which looks like a light emitting diode, this sensor measures the light reflected from the surface of the IR filter.
- The communication to the flash is located on the hot shoe and basically consists of a ground connector and a signal pin. This description is simplified as there also are communications e.g. for turning on the AF assist LED.

The below written text is a walk-through of most actions happening when using TTL flash photography

1. Exposure mode is selected (lets take manual, aperture f/8 and 1/60th of a second)
2. The shutter release is pressed half way
3. The camera body focuses
4. The camera body calculates the amount of light needed to expose according to the ISO set by the Digital back
5. The flash unit is queried for ready state
6. The flash unit answers with ready signal
7. The shutter release button is fully pressed
8. The aperture is set to the correct position
9. The first shutter curtain is raised
10. The camera body starts measuring the light reflected from the IR filter
11. The camera body is raising the flash signal and the flash turns on
12. The camera body still measures the light
13. When the right amount of light has been detected by the camera body the flash signal is turned off, regardless of how much exposure time is left
14. The exposure time runs out
15. The second shutter curtain is lowered

The flash unit is working as a slave being turned on and off by the camera body, this is the way most cameras work - If Av or Tv is selected a factor is missing and the flash will not know which aperture or time to select, without actually performing a complete exposure cycle.

## Web resources.

You can find many resources on the internet providing in-depth or specialized information regarding Phase One and Capture One products.

Many resources and tutorials are created on voluntary basis, and Phase One is always interested in seeing your video, review, blog or website concerning Phase One.

Besides the user guides, available on [www.phaseone.com](http://www.phaseone.com) in updated high-res versions you can find the following resources approved by Phase One.

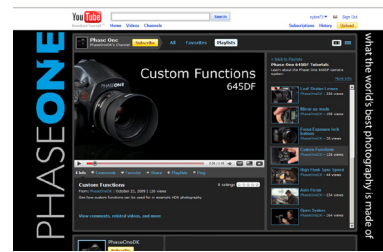
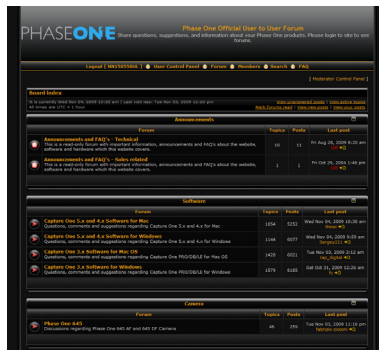

PhaseOneDK official Youtube channel  
Youtube channel providing access to tutorials, showcases, technical videos and much more.

Phase One Forum official  
The user forum is a traditional forum, you can share experiences and find a few tip'n'tricks.

Phase One Knowledge Base official  
Based on the extremely large database and experience of Phase One Support, the knowledge base can normally provide you the answer to almost any technical question.

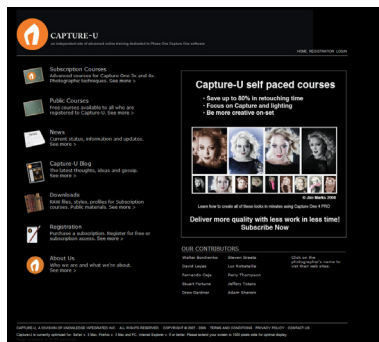

Capture-U.com - recommended by Phase One  
Founded by Walter Borchenko, Capture-U is providing a variety of educational texts and tests, based on RAW file workflow, mainly Capture One.

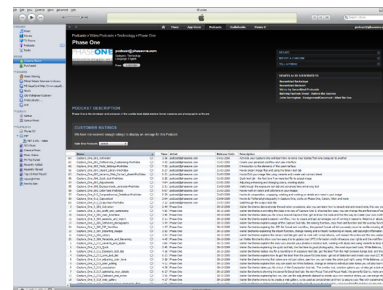

Phase One Podcast channel  
Tutorial videos, showcases, technical videos and much more - optimized for Ipod & Iphone.